

Customer Entries

Stitching head no:

Machine manufacturer:

Type of manufacturer:

Manufacturer' s Address

Company name: **hohner Maschinenbau GmbH**

Street: **Gänsäcker 19**

Town: **D-78532 Tuttlingen**

Telephone: **+49 7462 / 9468-0**

Fax: **+49 7462 / 9468-20**

Email: **info@hohner-gmbh.de**

Internet: **http://www.hohnerstitching.com**

Spare Parts / Customer Service

Service telephone no: **+49 7462 / 9468-23**

4.2.4.2	Replacing the circular knife	41
4.2.4.3	Adjusting the circular knife	41
4.2.5	Replacing the driver	43
5	FAULTS	44
5.1	Causes and elimination of faults	44
SPARE PARTS LIST		E1

1.4 Obligation and liability

The **Stitching Head M 45/6** has been built according to state-of-the art technology under observance of all the recognised safety regulations. However, dangers to life and limb of the user or third parties and damage to the system or other material assets can still occur during use. The stitching head should only be used,

- for the purpose for which it was designed
- when it is in a perfect technical condition.

Faults which could reduce levels of safety when using the machine must be eliminated immediately.

Warranties and liability on the part of the manufacturer are fundamentally covered by the regulations laid down in our "General sales and delivery conditions".

Warranty claims will only be valid if the number label is affixed (number label on stitching head housing).

1.5 Correct use

The **Stitching Head M 45/6** is designed exclusively for binding brochures and leaflets or similar items.

Any use of the machine contrary to that described above is forbidden, since incorrect use of the machine can present a danger.

1.6 Organisational measures

The user of machine is required to provide the required personal safety equipment. All existing safety devices should be checked regularly.

1.7 Safety and protective devices

All safety and protective devices must be correctly attached to the machine and should be in full working order before every start-up of the machine and **Stitching Head M 45/6**.

Safety and protective devices may only be removed:

- After the machine has come to a standstill **and**
- As security against the machine starting up again.

1.8 Non-formal safety measures

The Operating Manual must be kept so that it is permanently at hand at the machine with **Stitching Head M 45/6**. There are also generally valid local regulations concerning accident prevention and environmental protection measures which should be made available and observed in addition to those described in the Operating Instructions.

All safety and danger signs on the machine should be maintained in a legible condition and should be renewed where necessary.

1.9 Staff training

Only trained and instructed personnel may install, operate, set and maintain the stitching head.

2 Description of the Stitching Head

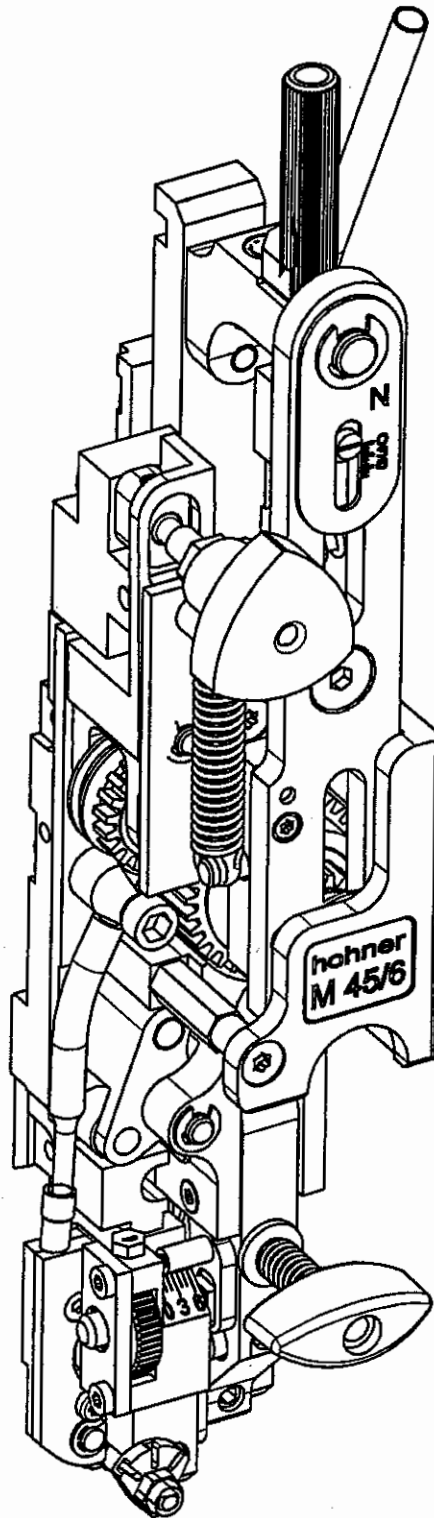
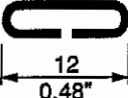

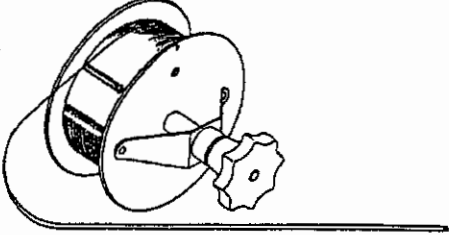
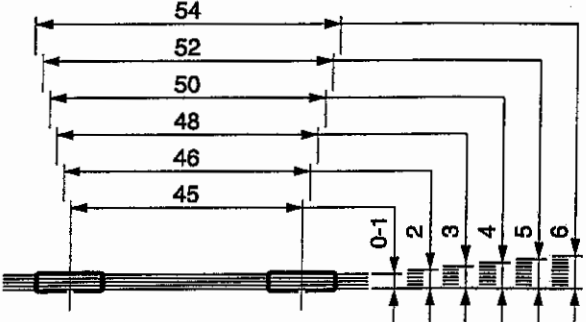
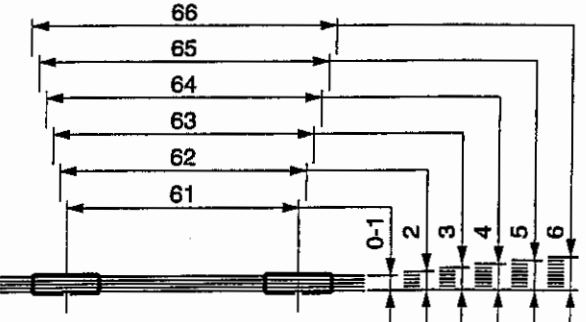
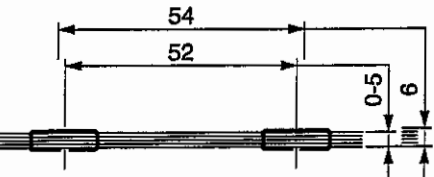

Fig. 1

2.4.1 Normal stitch

<p>Wire stitch dimensions</p>	
<p>Max. stitch thickness</p>	
<p>Round stitching wire No. 24 - 26 Ø 0.60 - 0.50 mm (Ø 0.024 - 0.020 in.)</p> <p>or:</p> <p>Round stitching wire No. 26 - 28 Ø 0.50 - 0.40 mm (Ø 0.020 - 0.016 in.)</p> <p>or:</p> <p>Round stitching wire No. 23 Ø 0.70 mm (Ø 0.027 in.)</p>	
<p>Possible distances between wire stitches and stitch thicknesses in mm</p>	
<p>With holding down device - standard -</p>	
<p>Optional: with holding down device, left</p>	

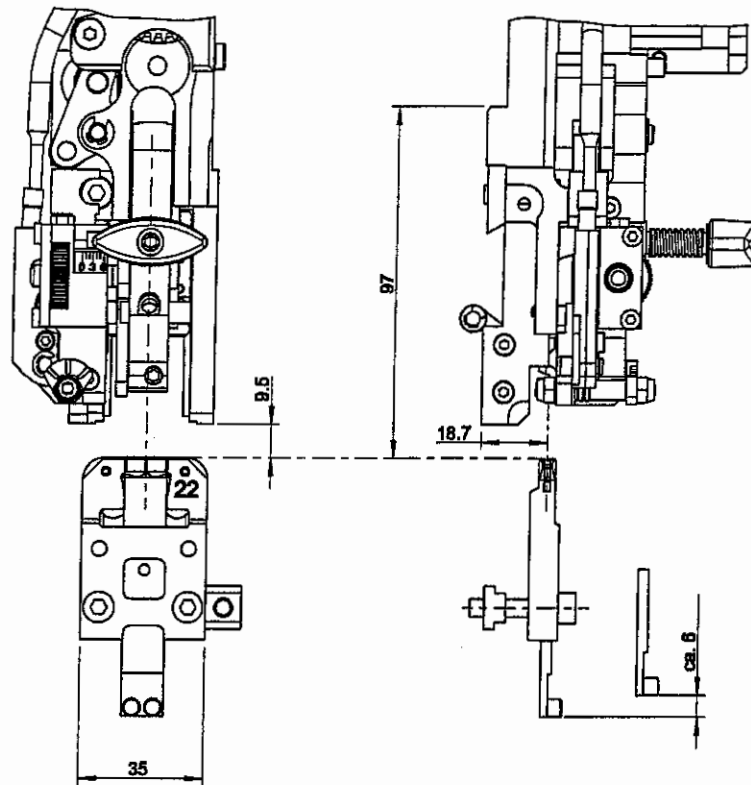

Fig. 3

2.5 Dimensional sheet

- Fig. 2 , Fig. 3-

2.6 Outfitting of the stitching head

2.6.1 Basic features

The stitching head is delivered with the following accessories:

DESCRIPTION	ORDER NUMBER
Clincher box adjustment gauge	31 64 448
Hexagon key SW 3	46 00 008
Allen key with T-handle SW4 x 150	46 00 033
Torx screwdriver T7	46 00 036
Torx screwdriver T10	46 00 044
Torx screwdriver T20	46 00 045
Adjusting handle	94 55 096
Holding down set, complete	99 55 090
Wire clamp, complete	99 55 150
Clincher box, complete	Depending on machine type

2.6.2 Additional equipment

The following optional accessories are available:

DESCRIPTION	ORDER NUMBER
Tenon block strip for stitching head - distance 80	31 59 014
Clamping strip for clincher box - distance 80	31 59 414
Holding down set, left - narrow version	99 55 075
Set of interchangeable parts for round wire no. 23	99 55 323
Set of interchangeable parts 24 -26	99 55 324
Set of interchangeable parts 26 -28	99 55 326
Pan area	99 55 515

3.1 Installation of the stitching head

3.1.1 Clamping the stitching head

- Fig. 4 -

The stitching head is held by a tenon block which is inserted into the stitching head mounting on the machine.

- Loosen tenon block ① with Allen key SW4 ⑤.
- Mount stitching head by laterally inserting the tenon block into the stitching head mounting ②.
The two driver lugs ③ on the stitching head must be located in the guides of the lifting bar.
- Fix stitching head in stitching head mounting by tightening the tenon block ① with the Allen key.

3.1.1.1 Lateral adjustment of the stitching head

- Fig. 4 -



The center of the wire formed parts within the stitching head must be set to the desired stitching position for the wire stitch by lateral adjustment.

- Loosen the tenon block ① with the Allen key ⑤.
- Move the stitching head sideways, until the desired position is reached.
- Fix the tenon block in the stitching head mounting ② with the Allen key.

3.1.2 Fitting the wire guide

- Fig. 5 -

- Loosen screw ① and place wire clamp ④ on wire guidance tube ②.
- Align wire clamp ④ with wire roller and wire feed tube ③, in order to ensure perfect wire guidance.
- Fix wire clamp ④ by tightening screw ①.

3.1.3 Fitting the clincher box

- Fig. 6 -

The procedure for fitting the clincher box is described in the stitching unit instruction manual.

3.1.4 Adjusting the clincher box

- Fig. 7 -

The center of the bender inside the stitching head must be precisely aligned with the center of the clincher box.

- Loosen clamping nuts ①.
- Move clincher box ② until it is precisely aligned with the center of the wire formed parts.
- Fix clincher box by tightening the clamping nuts.

Using the clincher box adjustment gauge

- Fig. 8 -

- Remove the former (see page 37). Place gauge ③ on former locating pin ④ and rotate downwards towards the stop. In this position the clincher box can be precisely adjusted by aligning the gauge with the scale marks on the clincher box.
- Tighten clamping nuts ① and remove gauge ③. Replace former.

3.2 Feeding the stitching wire

- Fig. 9 -

- Stop wire feed (move triangular handle ⑤ into "middle position").
- Push stitching wire through from above, as follows:
through the eye ① of the wire clamp – between the two felt disks ② into the hopper ③ – through the wire guidance tube ④ and between the two conveyor rollers ⑥.
- Restart the wire feed (turn triangular handle ⑤ to the left or right).
- Mount adjusting handle ⑦.
- Convey stitching wire by turning the adjusting handle ⑦ to the right as far as the knife.

3.3 Removing the stitching wire

- Fig. 9 -

- Stop wire feed (move triangular handle ⑤ into "middle position").
- Remove wire.

3.4 Removing the wire guidance sleeves in the event of a stitching wire jam

- Fig. 9 -

If a wire jam occurs in the area of the wire guidance sleeves, this will be easier to eliminate if you remove the wire guidance sleeves.

- Stop wire feed (move triangular handle ⑤ into "middle position").
- Loosen screw ⑨ and remove wire guidance sleeves ⑧
- Disentangle wire and remove from wire guidance sleeves.
- Remove wire.

3.5 Straighten the stitching wire

- Fig. 10 -

The stitching wire must run absolutely straight out of the circular knife. The wire feed can be set to run absolutely straight by turning the wire alignment roller ① which is arranged on eccentric bearings.

Wire straightening procedure:

- First remove former. (cf. 4.2.1)

a) Activate the machine's jog switch if possible.

b) Manual wire feed (cf. 3.2 Feeding the stitching wire)

Wire can be fed by turning the provided adjusting handle in the clockwise direction. When doing this, it is a good idea to cut off any overlong pieces of wire, by pressing down the knife slider ③.

(Made easier by levers on the cutting rocker ④)

- Turn eccentric fixing of the wire alignment roller ① with the screwdriver until the stitching wire runs absolutely straight out of the circular knife.

3.6 Setting the stitch length

3.6.1 Basic setting of the stitch length

- Fig. 11 -

The setting is dependent on the thickness of the brochure sheets. Adjust notch on scale ③ by turning the knurled nut ①. One graduation line corresponds to approx. 1 mm stitch thickness. A slight correction may be necessary after changing the wire thickness.

Normal stitching:

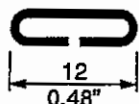

The recommended wire length for 2-sheet stitching is approx. 23 mm, the stitching unit must then be set to 2-sheet stitching.

3.6.2 Fine adjustment of the stitch length

- Fig. 11 -

Fine adjustment of the wire length is performed by means of test stitches. If the stitch is not the required length, more wire can be fed by **turning knob ① anticlockwise (+)**, or less wire can be fed by **turning the knob anticlockwise (-)** (cf. scale ②).

1 revolution of the knob feeds around 2 mm wire.

3.6.3 Setting the leg length of the stitch

- Fig. 12 -

The leg length of the stitch is dependent on the thickness of the product to be stitched. The knife box ① can be adjusted in order to adapt to the thickness of the product. The end of the scale pin ③ marks the set value for the stitch thickness in mm on the scale ④ (0 - 6)..

- Adjust knife box ① by turning the knurled wheel ②, until the end of the pin ③ indicates the value of the required stitch thickness (in mm) on the scale.
- Test the leg length by a test stitch.
- Set the stitch to precisely the same leg length by turning the knurled wheel ②.

Normal stitch



move thumbwheel up



move thumbwheel down

3.7 Setting the former

- Fig. 13, Fig. 14 -

To guarantee perfect stitching, the former ③ must swivel in far enough for the stitching wire (arrow B) to be positioned exactly beneath the center of the groove (arrow A) of the bender ①.

A mirror ⑤ placed on the clincher box can be used to check the setting on the fitted stitching head. The former ③ must keep the wire (arrow B) exactly aligned with the groove (arrow A) of the bender ①.

- Loosen the clamping screw ②.
- Turn the eccentric former stop ④ until precisely aligned.
- Tighten the clamping screw ②.



When changing the stitching wire thickness, the former setting should be checked and corrected if necessary.

3.8 Spine centering parts

The centering parts are only used for saddle stitching. They serve to precisely position the staple ① in the fold centre of the sheets ② (- cf. 15 -)

3.8.1 Installing the holding down device (standard version)

- Fig. 17 -

- In order to install the holding down device ⑪, insert the guide pin into the borehole on the bender and tighten the fastening screw ⑫.

3.8.2 Adjusting the holding down device (standard version)

- Fig. 17 -

- The centering prism ⑮ can be moved back and forth by turning the adjusting screw ⑭.
- Move the centering prism ⑮ backward or forward until it is precisely aligned with the prism of the slider ⑯.
 - Adjust the height of the prism ⑯ (approx. 0.5 mm above the clincher box) by moving it in the slot and tighten the fastening screw ⑰.

3.8.3 Installing the holding down device (optional narrow version)

- Fig. 16 -

- In order to mount the holding down device, screw the spring bolt ④ into the borehole on the stitching head.
- Insert extension spring into spring bolt ④ and lifting rod ⑥.
- Fix holding down device by screwing fastening screw ③ to lifting rod ⑥ and flange bushings ⑤ on the stitching head.
- Make sure that the lifting rod moves smoothly.
- Installing the carrier ⑱ in the main slide bar - see SPARE PARTS LIST page E27.

3.8.4 Adjusting the holding down device (optional narrow version)

- Fig. 16 -

- The centering prism ⑧ can be moved back and forth by turning the adjusting screw ⑦.
- Move the centering prism ⑧ backward or forward until it is precisely aligned with the prism of the slider ⑨.
 - Adjust the height of the prism ⑨ (approx. 0.5 mm above the clincher box) by moving it in the slot and tighten the fastening screws ⑩.

4.1 Lubrication

- Fig. 18 -

After approx. 16 operating hours, the stitching head must be lubricated with the lubricants described below.

The felt disks of the wire feed spring must also be lightly lubricated from each day.



If the stitching head is not regularly lubricated, greater wear will occur, the service life of the stitching head will be considerably decreased and premature failure of the stitching head may occur.

The magnet ① in the former should be cleaned from time to time, in order to ensure optimal wire holding force.

4.1.1 Lubricants

Lubricating grease for guideways and friction points:

High temperature high performance grease

Recommendation: RIVOLTA s.k.D. 4002 (100 gr.) - Order no. 96 90 016

Oil for felt disks:

Guideway oil with viscosity class 65-70 (ISO- viscosity class in accordance with DIN 51 519).

4.1.2 Lubrication plan

<i>Date</i>	<i>Operating hours status - display on stitching unit</i>	<i>Oil or grease used</i>	<i>Performed by: Name Signature</i>

4.2.1 Replacing the former

- Fig. 19, Fig. 20 -

- Push in clamping handle ① slightly and rotate by 90°. Remove former ② forwards.

Installation occurs in the reverse order. Make sure that the former is correctly positioned on the bolt ③.

- Adjust former according to Chap. 3.7.

4.2.2 Removing the bender stop

- Fig. 21, Fig. 22 -



The driver ② can be used on both sides. If one side is damaged or worn, the driver can be turned round.



Driver and bender are numbered. You must ensure that only drivers with matching benders (see table below) are used, as their wire guidance grooves vary.

Round wire no. 24 - 26 Driver : 31 55 334	with bender: 31 55 324
Round wire no. 26 - 28 Driver : 31 55 336	with bender: 31 55 326
Round wire no. 23 Driver : 31 55 334	with bender: 31 55 323

To replace or turn the driver, the central slide must be pulled down completely (arrow A).

- Remove central slide with driver ② downwards from stitching head (arrow A).
- Remove driver ② from driving pin ③.
- Turn or replace driver ②.

Installation occurs in the reverse order.

4.2.3 Replacing the bender

- Fig. 21, Fig. 22 -

To replace or turn the bender, the main slide ① must be pulled down completely (arrow A).

- Remove main slide ① with bender ⑥ downwards from stitching head (arrow A).
- Remove bender ⑥ by loosening the screws ⑦.
- Remove stop prism ⑥ by loosening the screws ⑤
- Turn or replace bender ⑥.

Installation occurs in the reverse order.

4.2.4 Replacing the knife

- Fig. 23 -

- To replace the knife, move the knife box ① completely away from the guide ③ by turning the knurling wheel ② and remove from the stitching head.

- Fig. 24 -

- Push the knife slider ⑤ out of the knife box ① (arrow A)
Make sure that the pressure spring doesn't strip.



- Change the knife (see following chapter)

- Fig. 26 -

- Replace knife slider ⑤ in the knife box ① (arrow B), compressing the pressure spring of the knife slider with a screwdriver, and pushing it into the knife box. Make sure that the pressure spring is not bent.



- Fig. 23 -

- Place knife box ① on the guide ③.
- Attach flexible wire feed to drill hole ④ in knife box.
- Return knife box to the desired position by turning the knurling wheel.



4.2.4.1 Rotating/Changing the flat knife

- Fig. 25 -

The flat knife has 2 cutting edges. Each cutting edge can be used three times by means of rotation.

- Loosen and unscrew fastening screw ⑨.
- Rotate or replace flat knife ⑧ and tighten fastening screw ⑨.



TIP

4.2.4.2 Replacing the circular knife

- Fig. 25 -

- Set position of the wire straightening eccentric ⑩ to the left until the clamping screw ⑥ is accessible.
- Loosen the clamping screw ⑥ and remove the circular knife ⑦.
- Press new circular knife completely into the seat in the knife box.
- Adjust circular knife (cf. Adjusting the circular knife).

4.2.4.3 Adjusting the circular knife

- Fig. 27 -

The circular knife is adjusted so as to ensure clean cutting of the wire.

When the knives are mounted, set the clearance between the flat and circular knives by carefully "levering" with a screwdriver.

- Loosen clamping screw ⑥ and position circular knife ⑦ exactly against the flat knife by "levering" with a screwdriver.
- Tighten clamping screw ⑥.
- After having installed the knives box ① align the stitching wire according to chapter 3.5 if necessary.



If the distance between the knives is set too close the knife slider 5 may block and cause a wire jam.









4.2.5 Replacing the driver

- Fig. 28 -

- Unscrew locking screw ⑤.
- Remove clincher ram ④ downwards.
- Turn clincher ① upwards in clincher box ③ and remove from the locking pin ②.
- Push new clincher onto the locking pin and turn to center of clincher box.
- Re-introduce clincher ram.
- Screw in and tighten locking screw ⑤.

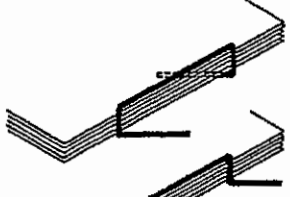
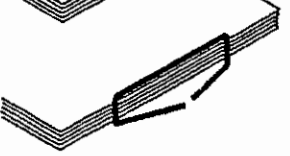

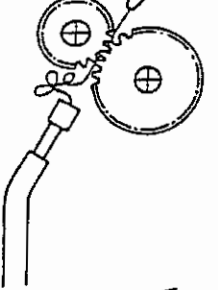
Make sure that you use the right screw-in side of the locking screw ⑤.

	<p>Stitch legs break off:</p>	<ul style="list-style-type: none"> - Wire too brittle: use a different wire quality. - Former blocked by pieces of wire: remove wire pieces, remove former if necessary. - Gripper spring or gripper in former defective. - Wire thickness not suitable for the wire guiding parts (bender and driver). - Adjust former to bender groove.
	<p>Hump at a stitch corner:</p>	<ul style="list-style-type: none"> - Weak or soft wire. - Driver damaged, cf. 4.2.2. - Circular or flat knife worn, cf. 4.2.4. - Wire not aligned, cf. 3.5. - Circular or flat knife worn, cf. 4.2.4.
	<p>Stitch legs contract or diverge:</p>	<ul style="list-style-type: none"> - Wire not aligned, cf. 3.5. - Align clincher box, cf. 3.1.4.
	<p>Leg ends clinched the wrong way round:</p>	<ul style="list-style-type: none"> - Weak or soft wire. - Wire not aligned, cf. 3.5. - Circular or flat knife worn, cf. 4.2.4.
	<p>One or both legs are clinched obliquely:</p>	<ul style="list-style-type: none"> - Clincher damaged, cf. 3.1.3. - Adjustment of clincher box mounting to stitching head mounting, cf. 3.1.4. - Wire not aligned, cf. 3.5.
	<p>Stitch legs are clinched obliquely to the same side:</p>	<ul style="list-style-type: none"> - Adjustment of clincher box mounting to stitching head mounting, cf. 3.1.4. - Wire not aligned, cf. 3.5. - Bender worn, cf. 4.2.3.
	<p>Lightly bent wire pieces fall out:</p>	<ul style="list-style-type: none"> - Wire not aligned, cf. 3.5. - Cutting slider jammed: circular knife set too tightly to flat knife, cf. 4.2.4.3. - Cutting rocker locked, pressure spring in cutting block defective.
	<p>Wire loop between conveyor wheels and wire guidance tube:</p>	<ul style="list-style-type: none"> - Lower wire tube in cutting block has shifted: adjust slightly up or down. - Former incorrectly set, cf. 4.2.1.
	<p>Straight wire pieces fall out:</p>	<ul style="list-style-type: none"> - Weak spring pressure on former. - Wire not aligned, cf. 3.5. - Former set incorrectly, cf. 4.2.1.

Ersatzteilliste - Spare parts list - Liste des pièces de rechange -
Lista die pezzi di ricambio - Lista de piezas de repuesto -
Lijst van Reserveonderdelen

hohner

M45/6

08/2006

Schmalheftkopf
Narrow Stitching Head
Tête de Piquage Étroite
Testa di cucitura in filo metallico
Cabezal cosedor de alambre
Smalle Draadhechkop

hohner
Maschinenbau GmbH
Gänsäcker 19
D-78532 Tuttlingen

Tel.: (+49) 7462 / 94 68 – 0
Fax: (+49) 7462 / 94 68 – 20
E-Mail: info@hohner-gmbh.de
Internet: www.hohnerstitching.com

hohner Maschinenbau GmbH - M45/6

- Technische Änderungen vorbehalten -
- modifications reserved -
- changements réservés -

ERSATZTEILELISTE

SPARE PARTS LIST

LISTE DES PIECES DE RECHANGE

Wichtig:

Bei Bestellung bitte angeben:

- Menge
- Art.-Nummer
- Heftkopf-Nummer

Attention:

In case of order please indicate:

- Quantity
- Art.-Number
- Number of Stitching Head

Attention:

En cas de commande veuillez s.v.p. indiquer:

- Quantité
- No. d'article
- No. de la tête de piquage

BITTE NUR ORIGINAL HOHNER ERSATZTEILE VERWENDEN

Bei Gebrauch von nicht Original hohner-Ersatzteilen erlischt der Garantieanspruch, sowohl die Verfügbarkeit und die Qualität leidet. Der Einsatz von Original hohner-Ersatzteilen garantiert ein einwandfreies Funktionieren.

ALWAYS INSIST ON GENUINE HOHNER REPLACEMENT PARTS

Use of non-hohner replacement parts will unconditionally void our factory warranty and may deteriorate the products performance and reliability. Use of genuine hohner parts will insure performance according to specifications and extend the live of associated components.

UTILISER UNIQUEMENT PIECES DE RECHANGE ORIGINAL-HOHNER

A l'usage des pièces de rechange qui ne sont pas de l'origine hohner la garantie s'étant et la disponibilité et la qualité souffrent. Seulement l'utilisation des pièces de rechange hohner-original garantie un fonctionnement parfait.

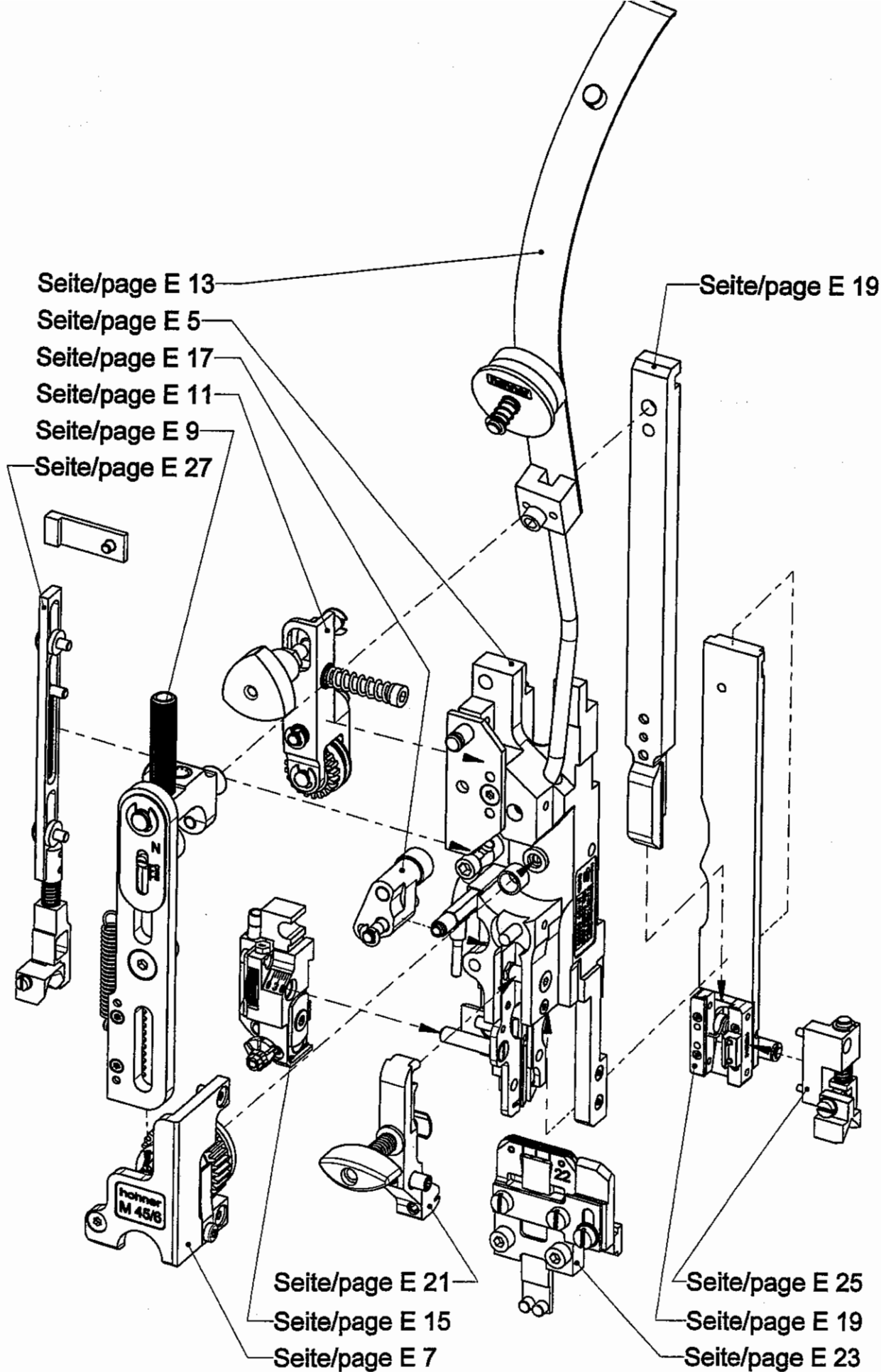

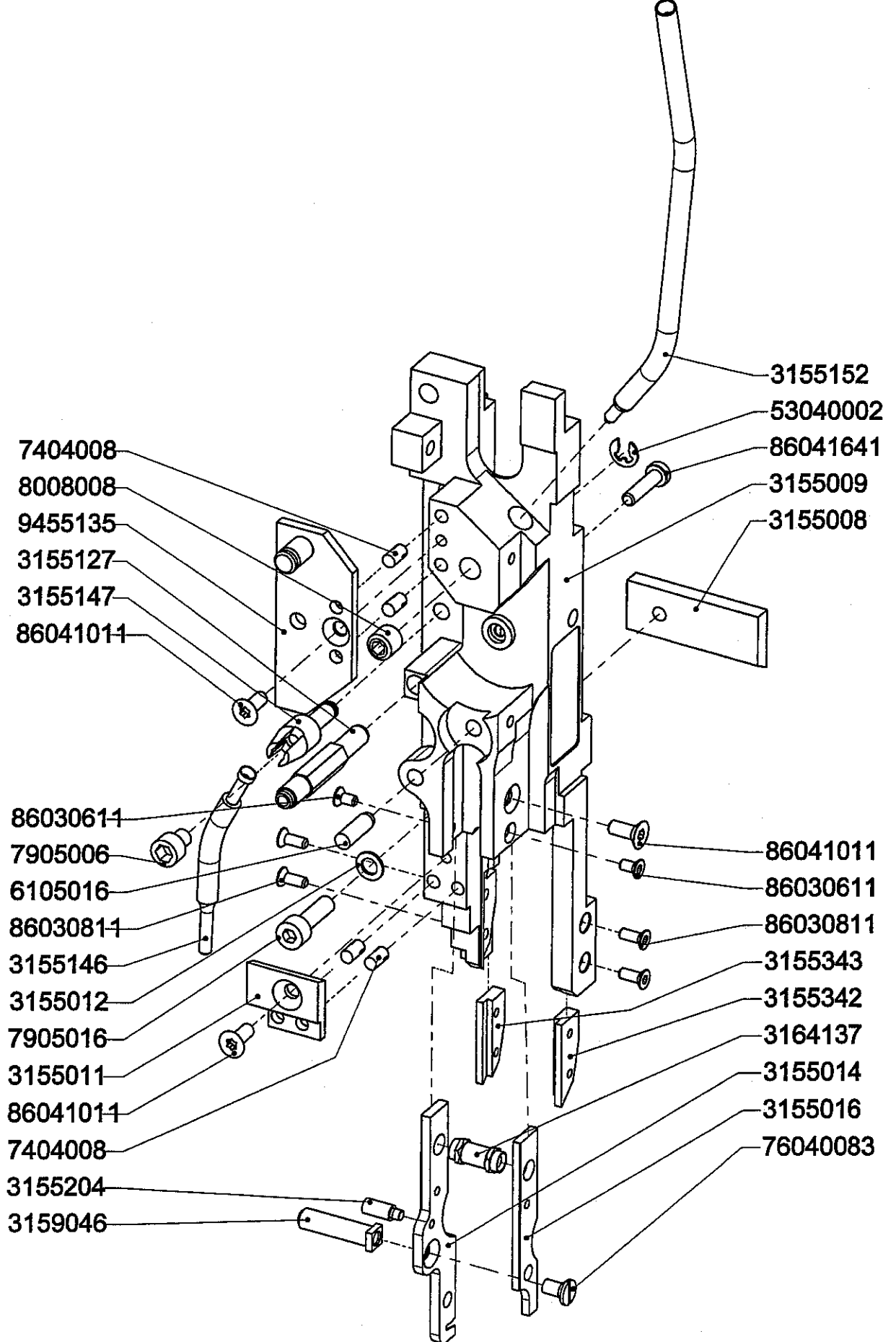

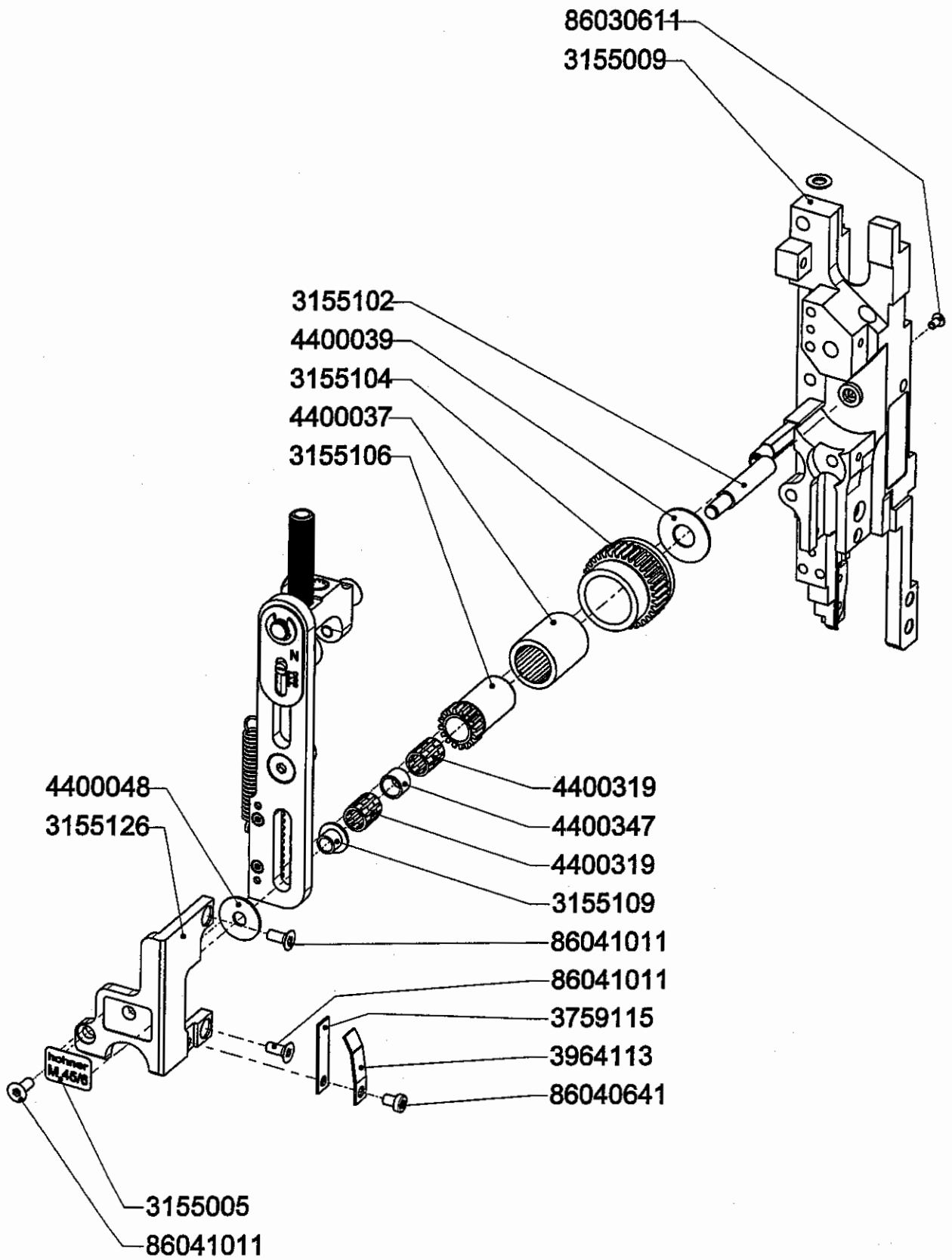

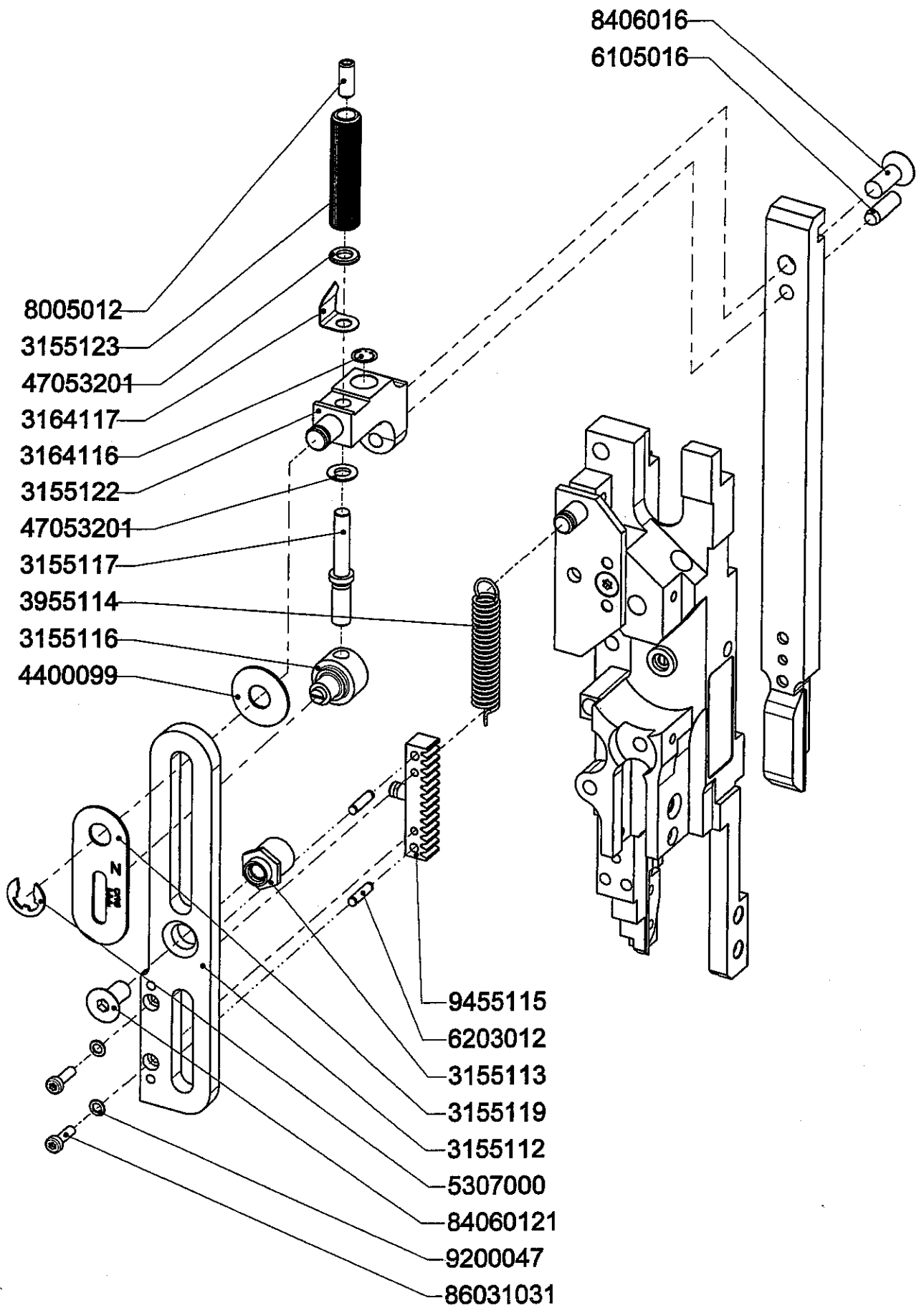

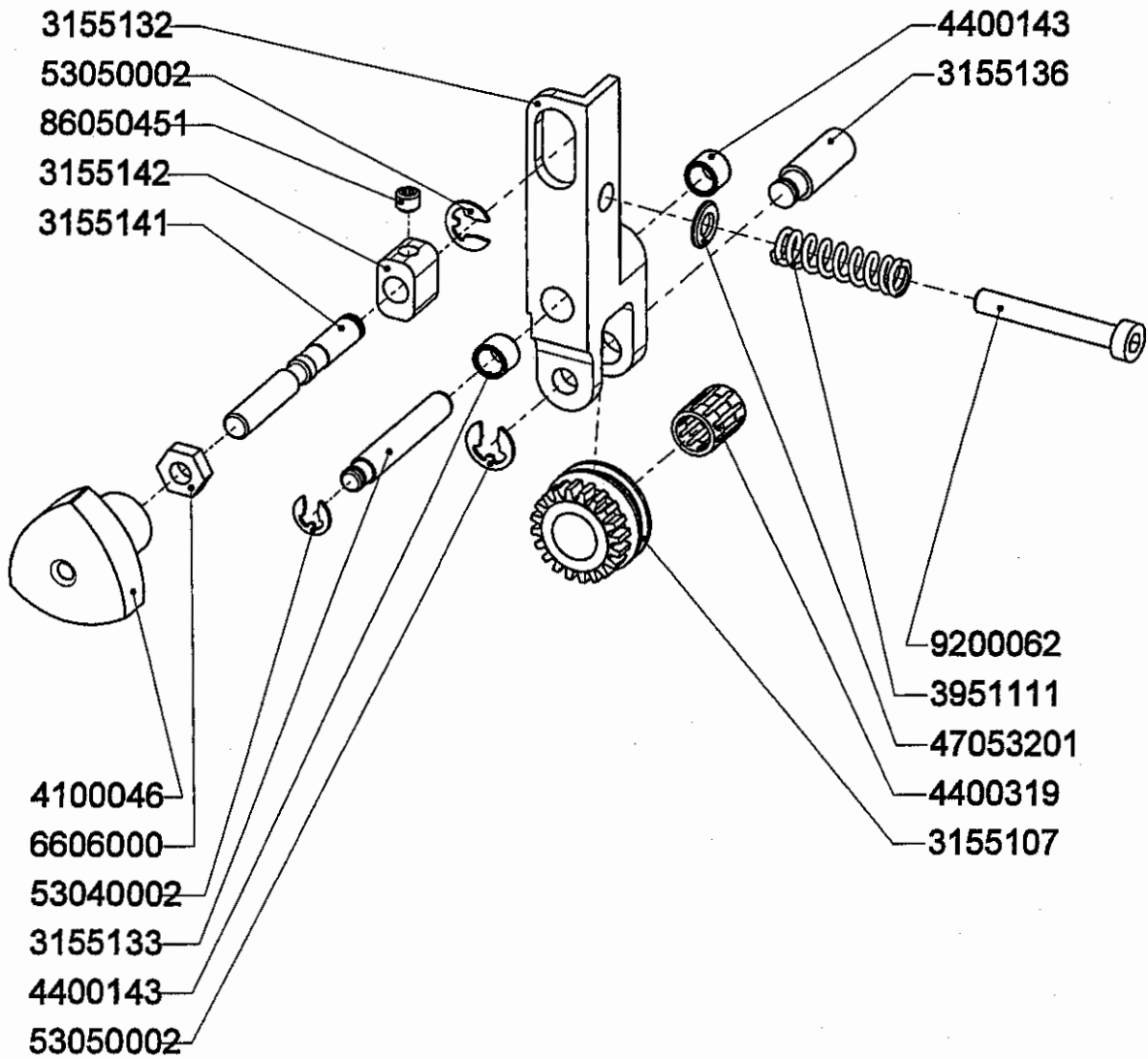

9955150

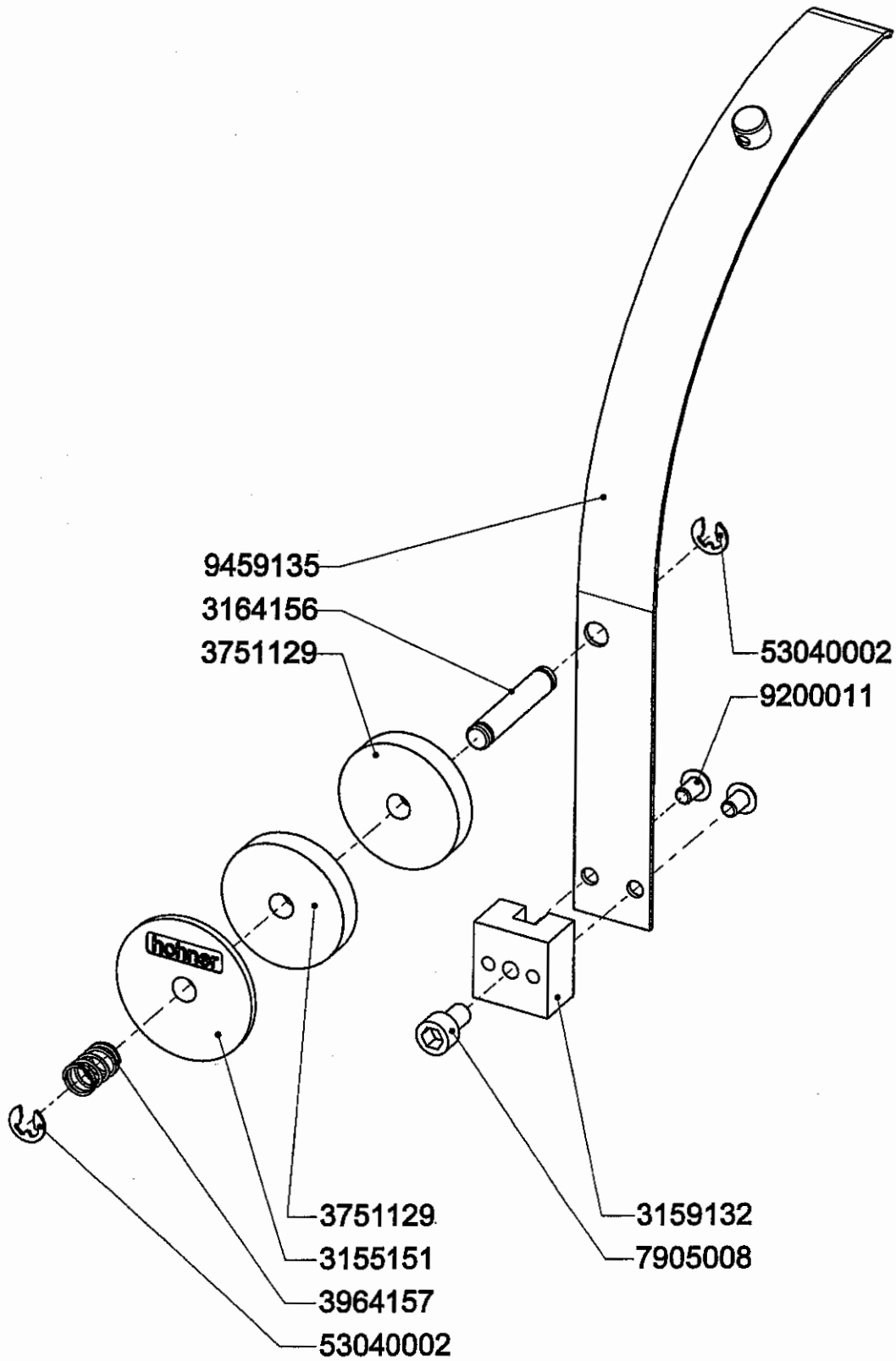

9955230

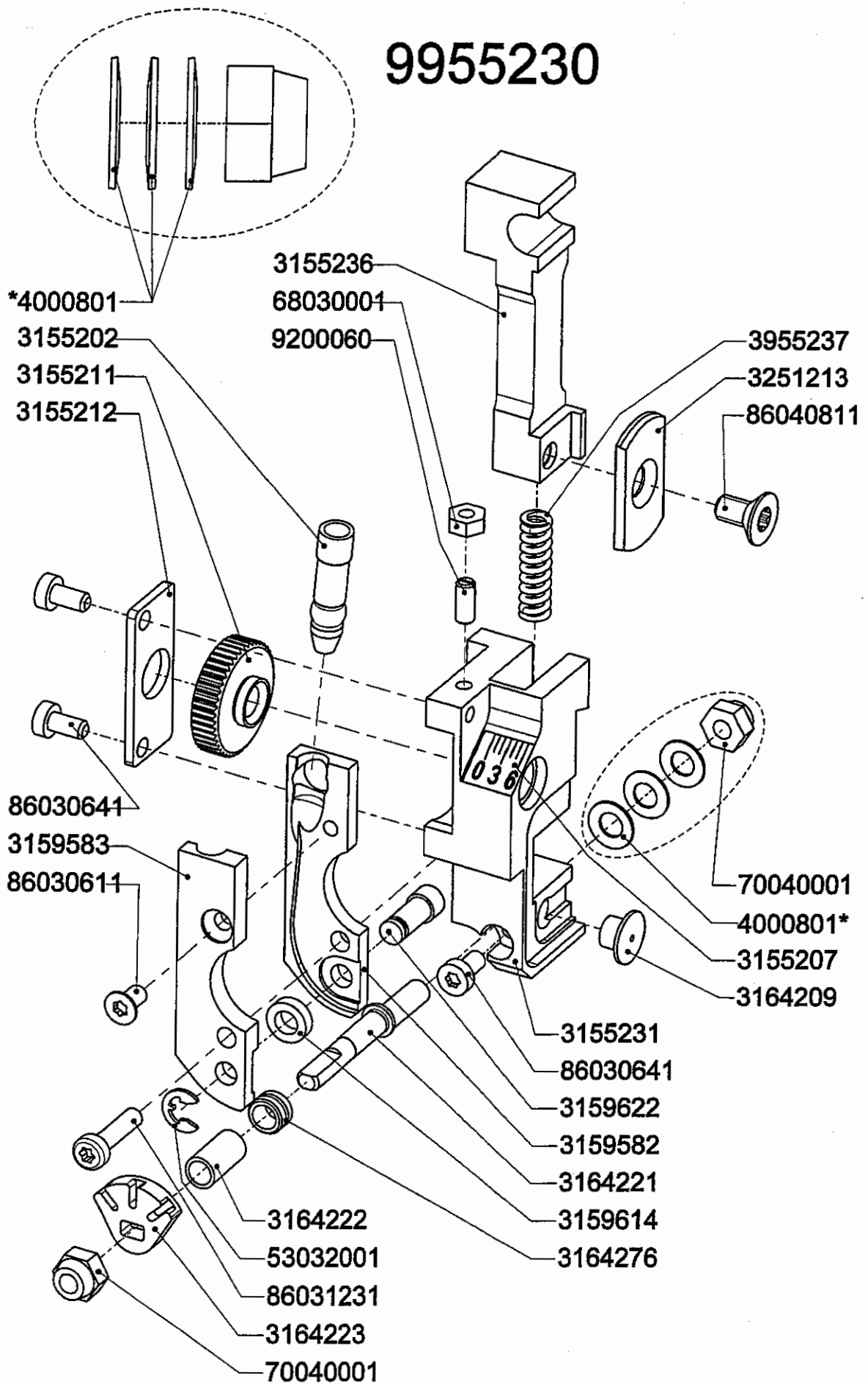

9955240

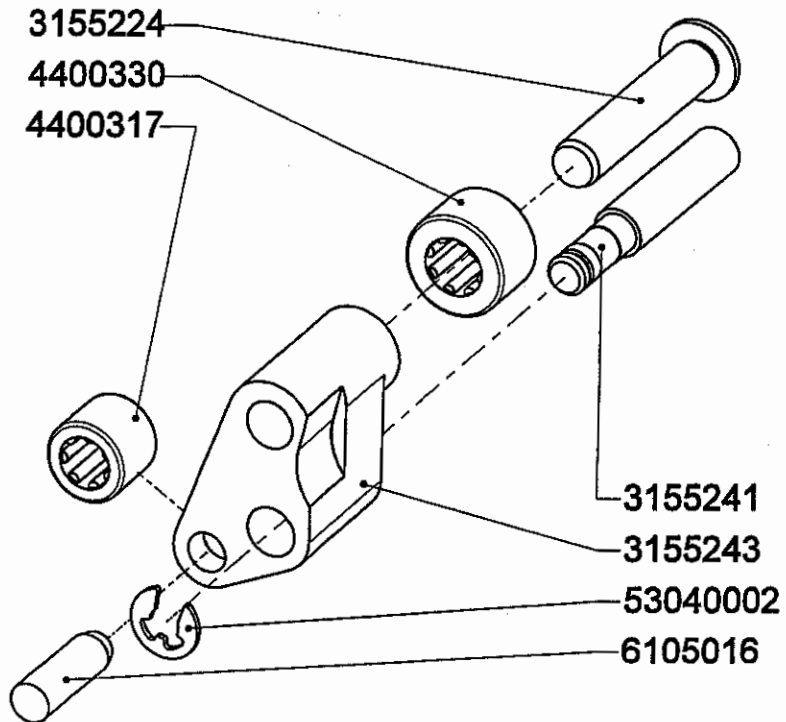

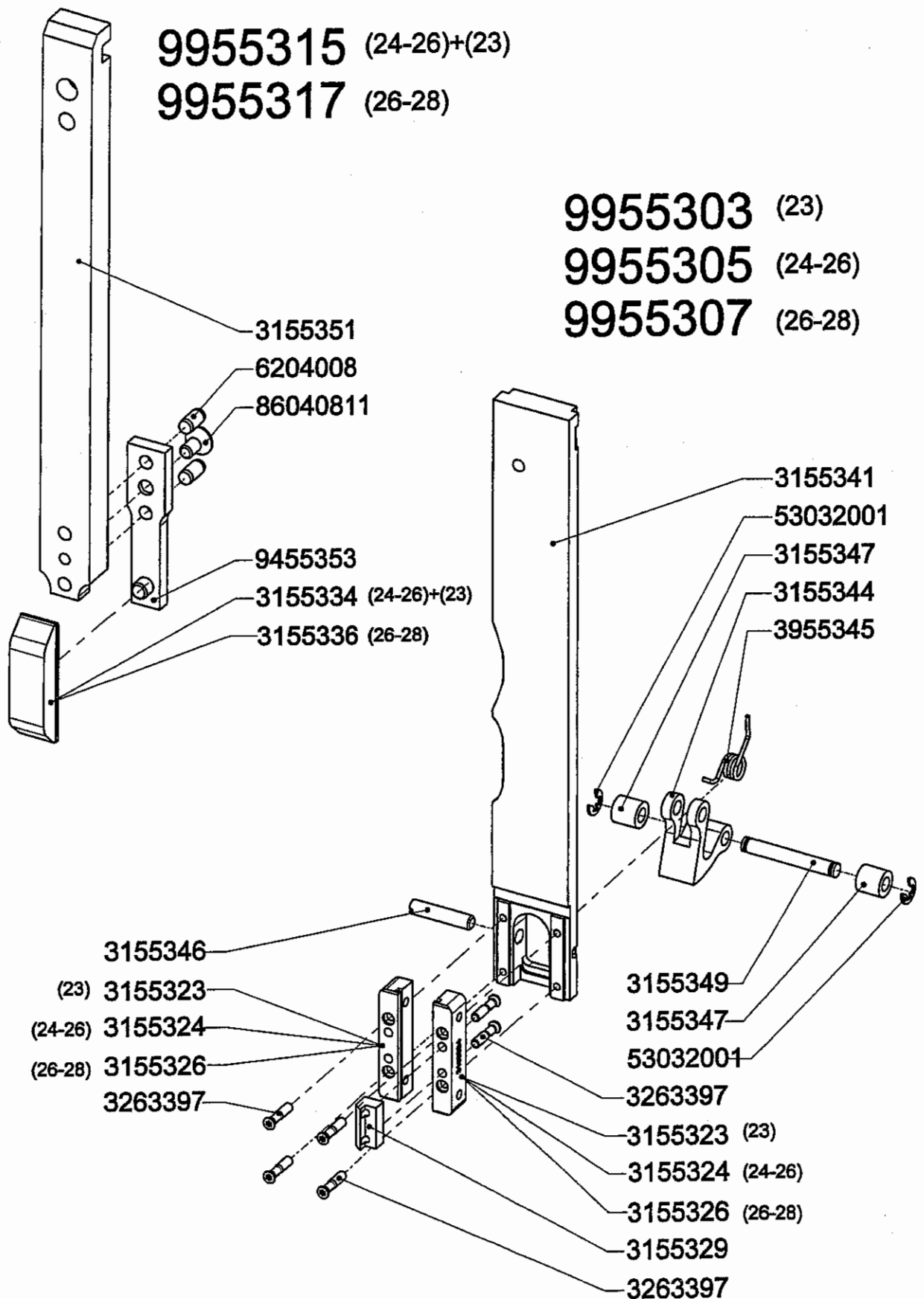

9955360

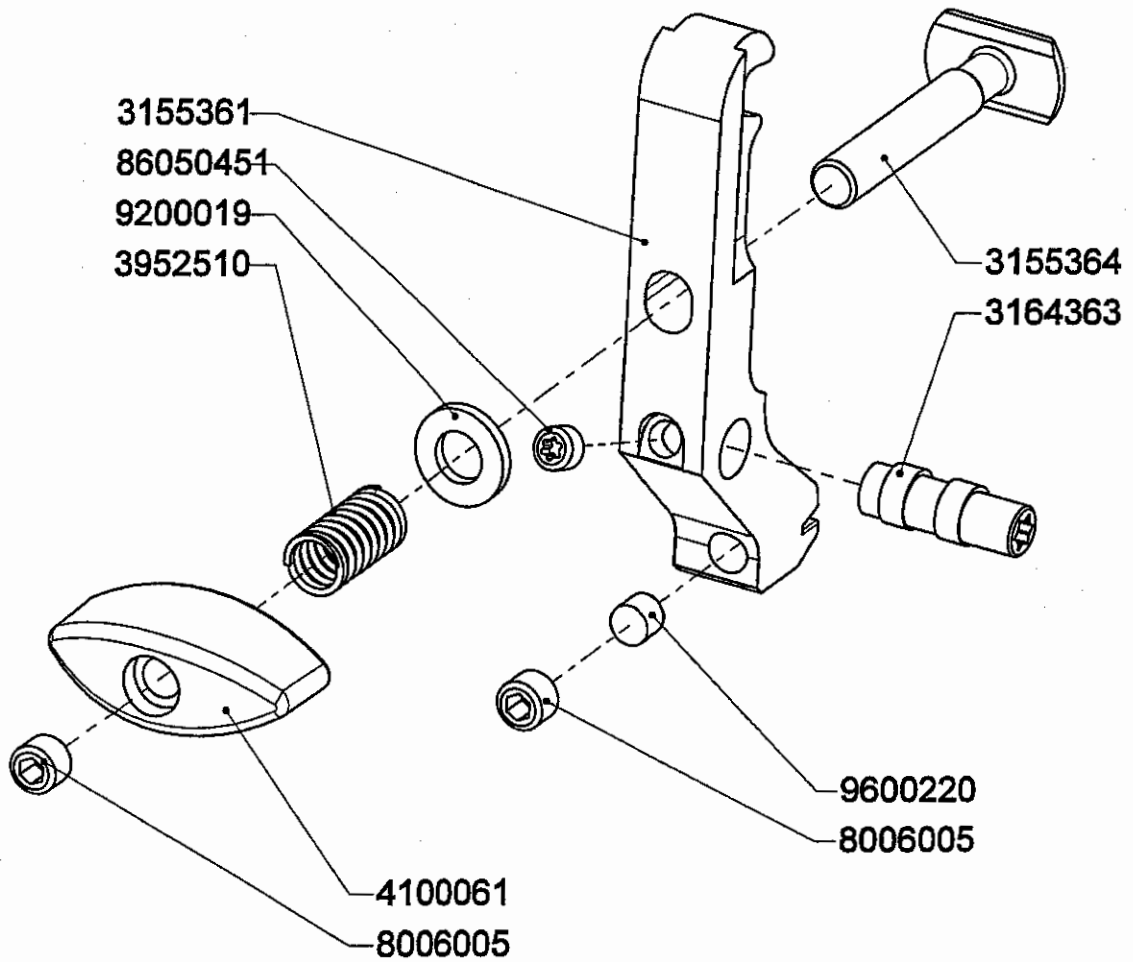

9955505 -Plus-

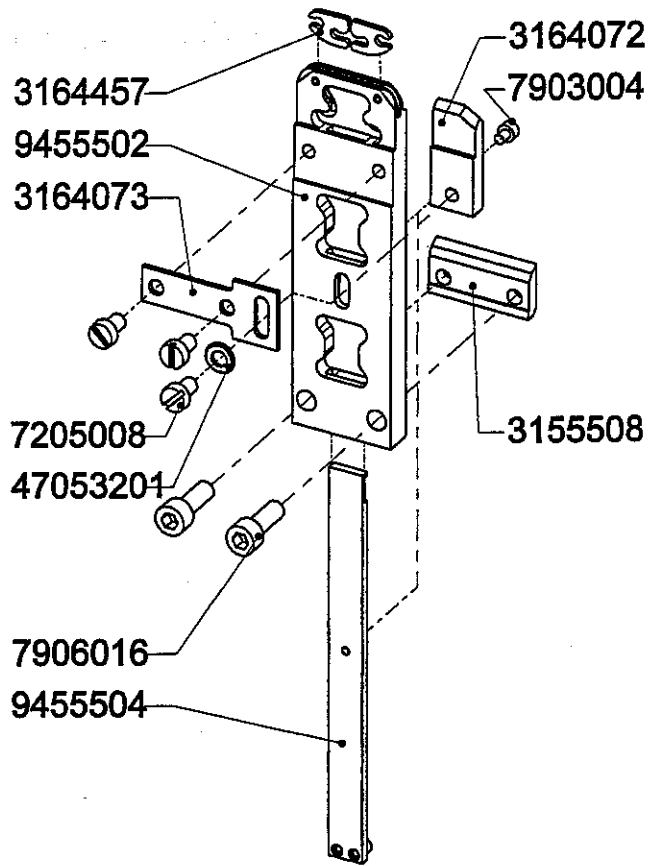

9955513

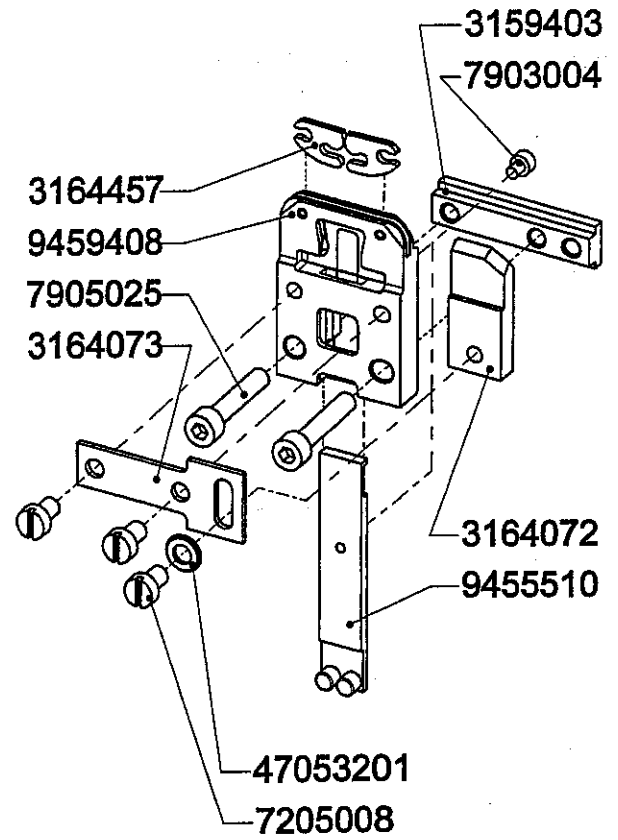

9955515

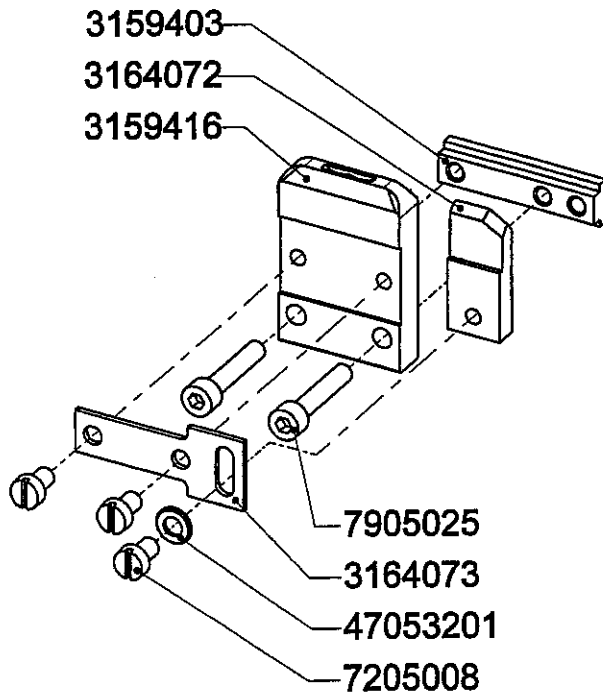

9959429 -Presto-

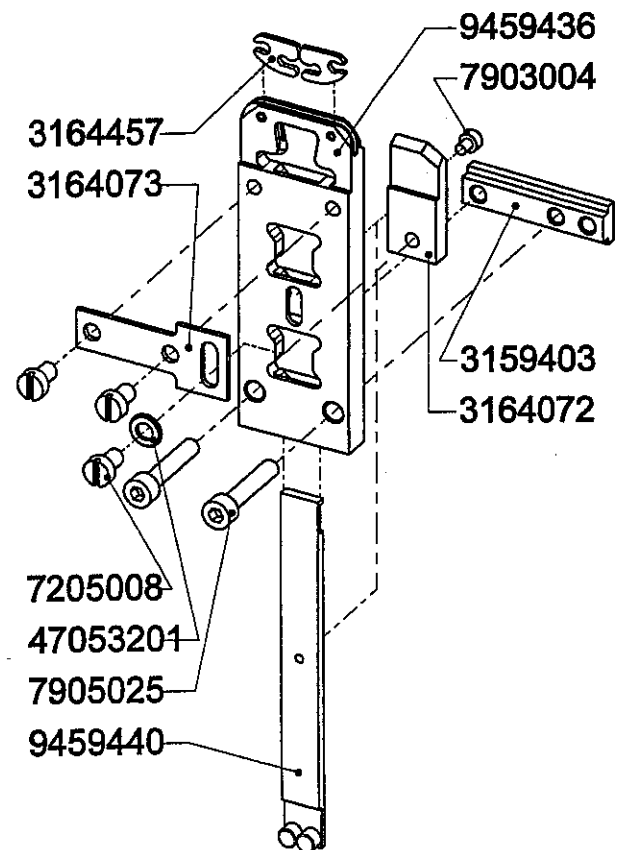

9955090

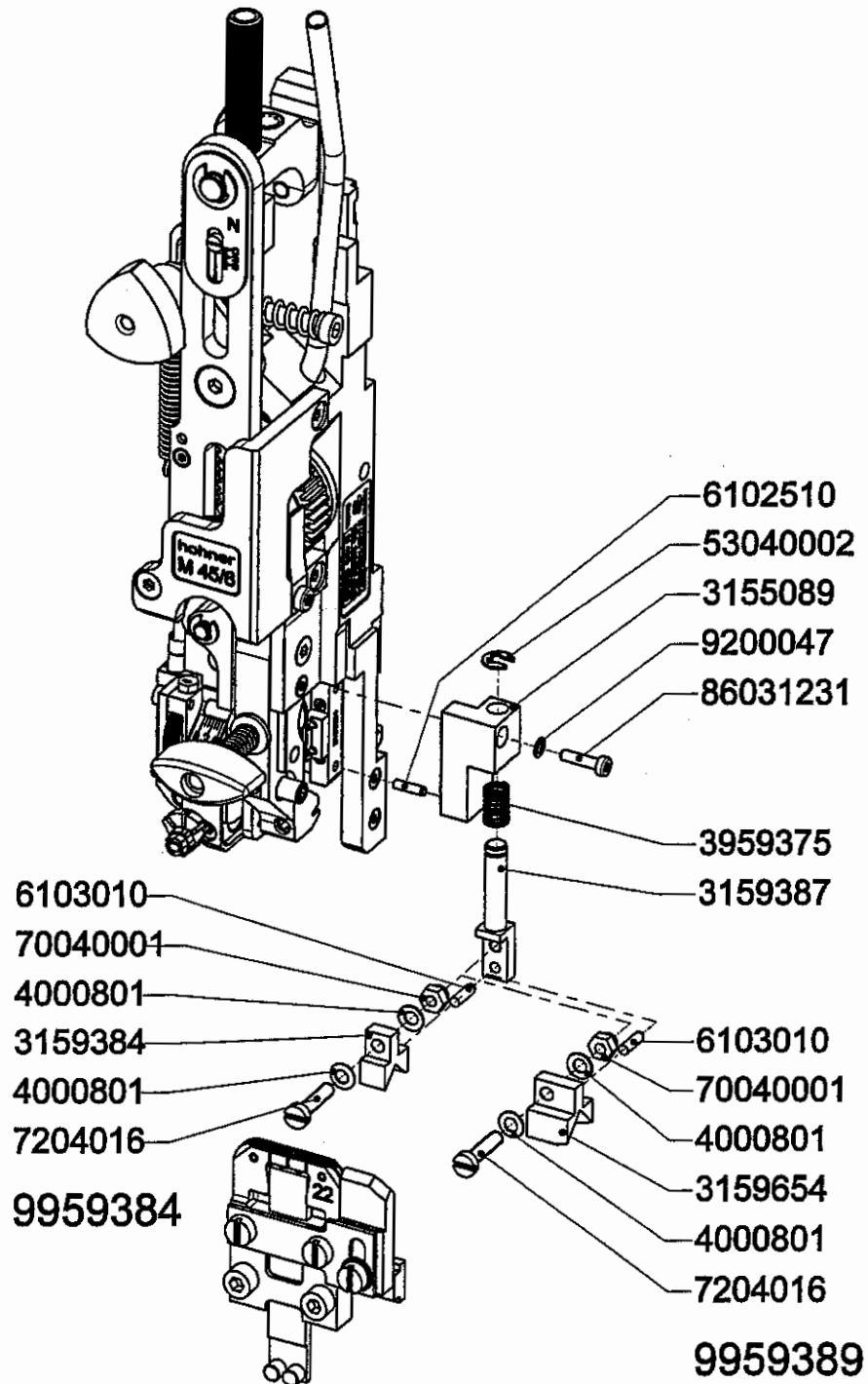

9955075

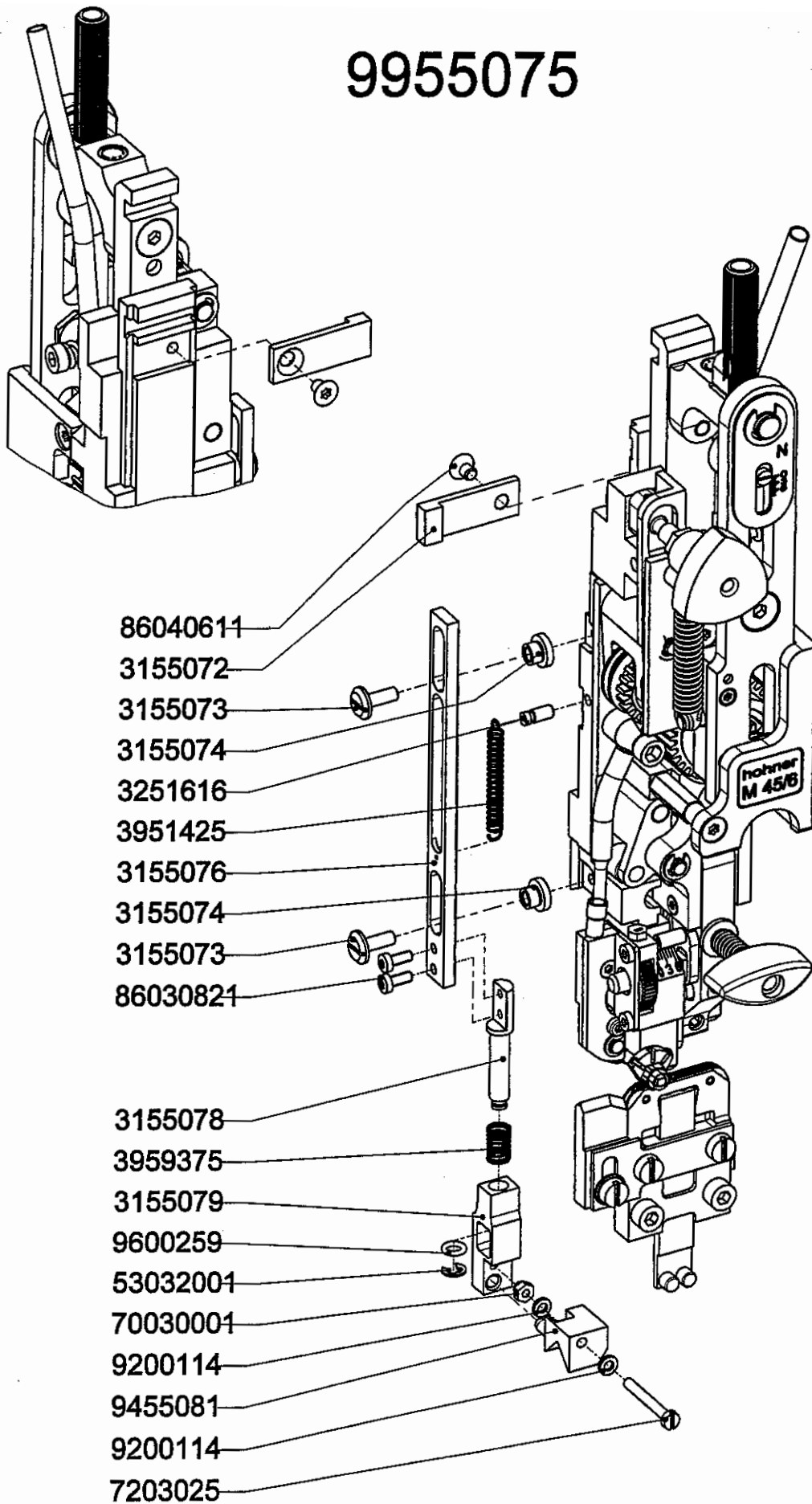

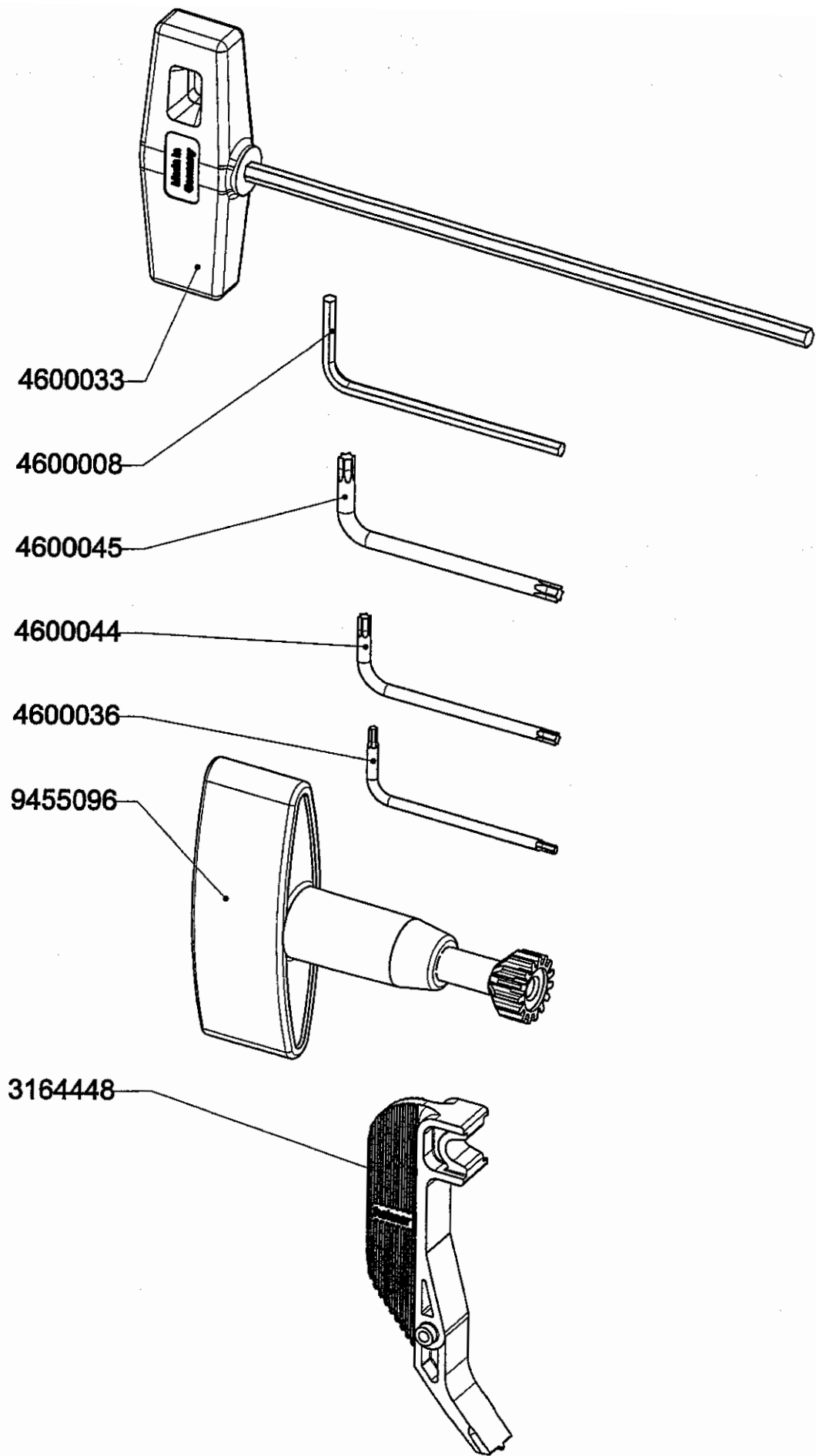

Optionen
Options
Opzioni
Opciones
Keuzemogelijkheden

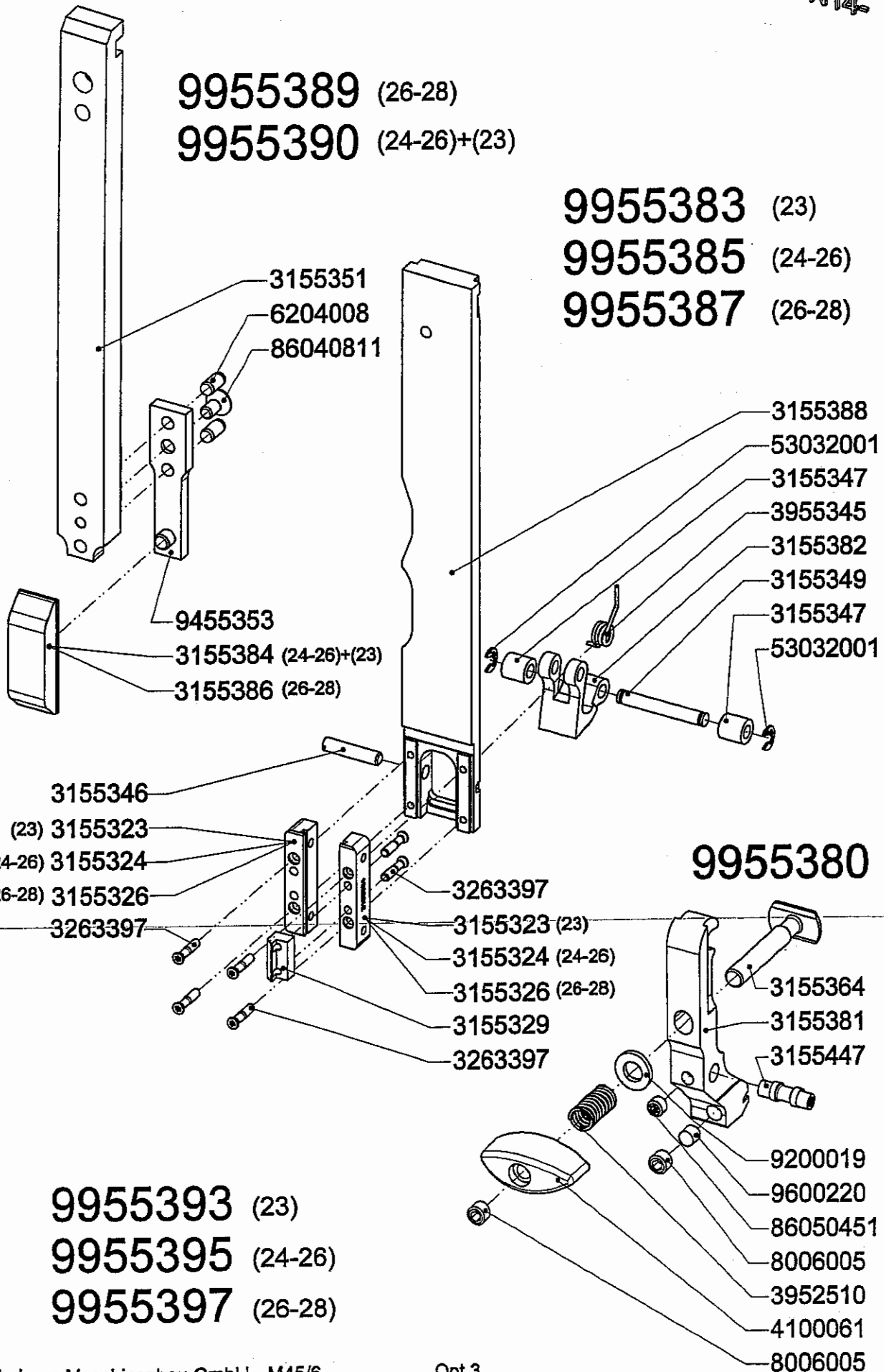

9955389 (26-28)

9955390 (24-26)+(23)

9955383 (23)

9955385 (24-26)

9955387 (26-28)

3155351
6204008
86040811

9455353
3155384 (24-26)+(23)
3155386 (26-28)

3155388
53032001
3155347
3955345
3155382
3155349
3155347
53032001

3155346
(23) 3155323
(24-26) 3155324
(26-28) 3155326
3263397

3263397
3155323 (23)
3155324 (24-26)
3155326 (26-28)
3155329
3263397

9955380

3155364
3155381
3155447

9200019
9600220
86050451
8006005
3952510
4100061
8006005

9955393 (23)

9955395 (24-26)

9955397 (26-28)