

OPERATION and MAINTENANCE MANUAL

For: 15001DHD Series, 18001D27HD Series
18001DHD Series, 18001DSHD Series

WIRE STITCHER HEADS

WARNING: BEFORE REMOVING OR SERVICING HEADS, TURN ELECTRICAL SWITCH "OFF" AND DISCONNECT THE SERVICE CORD FROM ELECTRICAL OUTLET.

TABLE OF CONTENTS

	PAGE
Table of Recommended Wire Sizes, Tolerances, and Tensile Strengths	2
Description	3
Operating Adjustments	4
Removing 15001DHD Series Heads	4
Attaching 15001DHD Series Heads	4
Removing 18001DHD Series and 18001D27HD Series Heads	4
Attaching 18001DHD Series and 18001D27HD Series Heads	5
Threading Wire	5
Straightening Wire	5-6
Adjusting Length of Staples	6
Maintenance	7
Lubrication	7
Removing Sliding Wire Cutter	7
Replacing Sliding Wire Cutter	8
Removing Stationary Wire Cutter	8
Replacing Stationary Wire Cutter	8
Removing Grip	8
Replacing Grip	9
Removing Driver	9
Replacing Driver	9
Disassembly and Reassembly	10
Disassembling Head	10
Reassembling Head	10-12
Trouble Shooting Chart	13
Formed Staples	13-14
Driven and Clinched Staples	15
Repair Parts	16
Explanation of the Parts List	16
Identifying and Ordering a Part	16
Parts List	17-22
Cross Reference from Part Number to Index Number	23

**TABLE OF RECOMMENDED WIRE SIZES,
TOLERANCES AND TENSILE STRENGTHS
FOR BEST STITCHING PERFORMANCE**

TYPE OF WIRE	WIRE GAUGE	WIRE SIZE AND TOLERANCE	TENSILE STRENGTH P.S.I.	OBTAINABLE CROWN SIZE
FLAT BOOKBINDER'S	18 x 20	+ .000 ± .0005 .0475 - .004 x .0348 + .0mm ± .01mm (1.2mm - .10mm x .86mm)	120,000 TO 150,000	1/2 (12.7mm)
	19 x 21-1/2	+ .000 ± .0005 .041 - .004 x .0301 + .0mm ± .01mm (1.0mm - .10mm x .76mm)		1/2 (12.7mm)
	20 x 24	+ .000 ± .0005 .0348 - .004 x .023 + .0mm ± .01mm (.86mm - .10mm x .58mm)		3/8 (9.5mm) 1/2 (12.7mm) 5/8 (15.9mm) 3/4 (19.1mm)
	21 x 25	+ .000 ± .0005 .0317 - .003 x .0204 + .0mm ± .01mm (.79mm - .08mm x .51mm)		1/2 (12.7mm)
ROUND BOOKBINDER'S	#18	.0475 ± .001 (1.2mm ± .03mm)	120,000 TO 150,000	1/2 (12.7mm)
	#20	.0348 ± .001 (.97mm ± .03mm)		1/2 (12.7mm) 5/8 (15.9mm)
	#23	.0258 ± .0005 (.65mm ± .01mm)		1/2 (12.7mm) 5/8 (15.9mm)
	#25	.0204 ± .0005 (.51mm ± .01mm)		3/8 (9.5mm) 1/2 (12.7mm) 5/8 (15.9mm) 3/4 (19.1mm)
	#27	.0173 ± .0005 (.43mm ± .01mm)		1/2 (12.7mm) 3/4 (19.1mm)
RIBBON	.020 (.51mm)	+ .002 ± .005 .103 - .008 x .020 + .05mm ± .13mm (2.6mm - .20mm x .51mm)	80,000 TO 105,000	1/2 (12.7mm) 5/8 (15.9mm) 3/4 (19.1mm)
HYBAR	#2	+ .002 ± .0005 .060 - .004 x .024 + .05mm ± .01mm (1.5mm - .10mm x .61mm)	80,000 TO 105,000	3/8 (9.5mm) 1/2 (12.7mm)

NOTE: Wires of Tensile strength other than those listed may be available and used as required to suit the particular application.

NOTE: When reference is made to any standard head series listed below, use the complete head symbol, which includes the maximum wire size and crown width.

EXAMPLE: The correct symbol for a 15001DHD series head with 20 x 24 flat wire, 1/2" (12.7mm) crown is 15001DHD2024-1/2.

15001DHD Series, 18001D27HD Series 18001DHD Series, 18001DSHD Series DESCRIPTION

The Bostitch 15001DHD series; 18001DHD series and 18001D27HD series Wire Stitcher Heads are basically identical with respect to operation. Variations in some of the component parts are due to adapting the basic head to single stitch and gang stitch machines.

The 15001DHD series heads are used only on single stitch machines, on the No. 14, 14B, or 15 Wire Stitcher.

The 18001DHD series and 18001D27HD series heads are used only on gang stitch machines; the

18001DHD series head on the No. 18 Multiple Stitcher, and the 18001D27HD series head on the No. 27 Multiple Stitcher.

The 18001DHD series and 18001D27HD series heads can be readily distinguished from the 15001DHD series heads, because they have keys in the mounting surfaces, three cut-outs in the right side of the bonnet, and bonnet clamp block eccentrics. (See Figure 1.)

Also, the 15001DHD series includes the Head Guard.

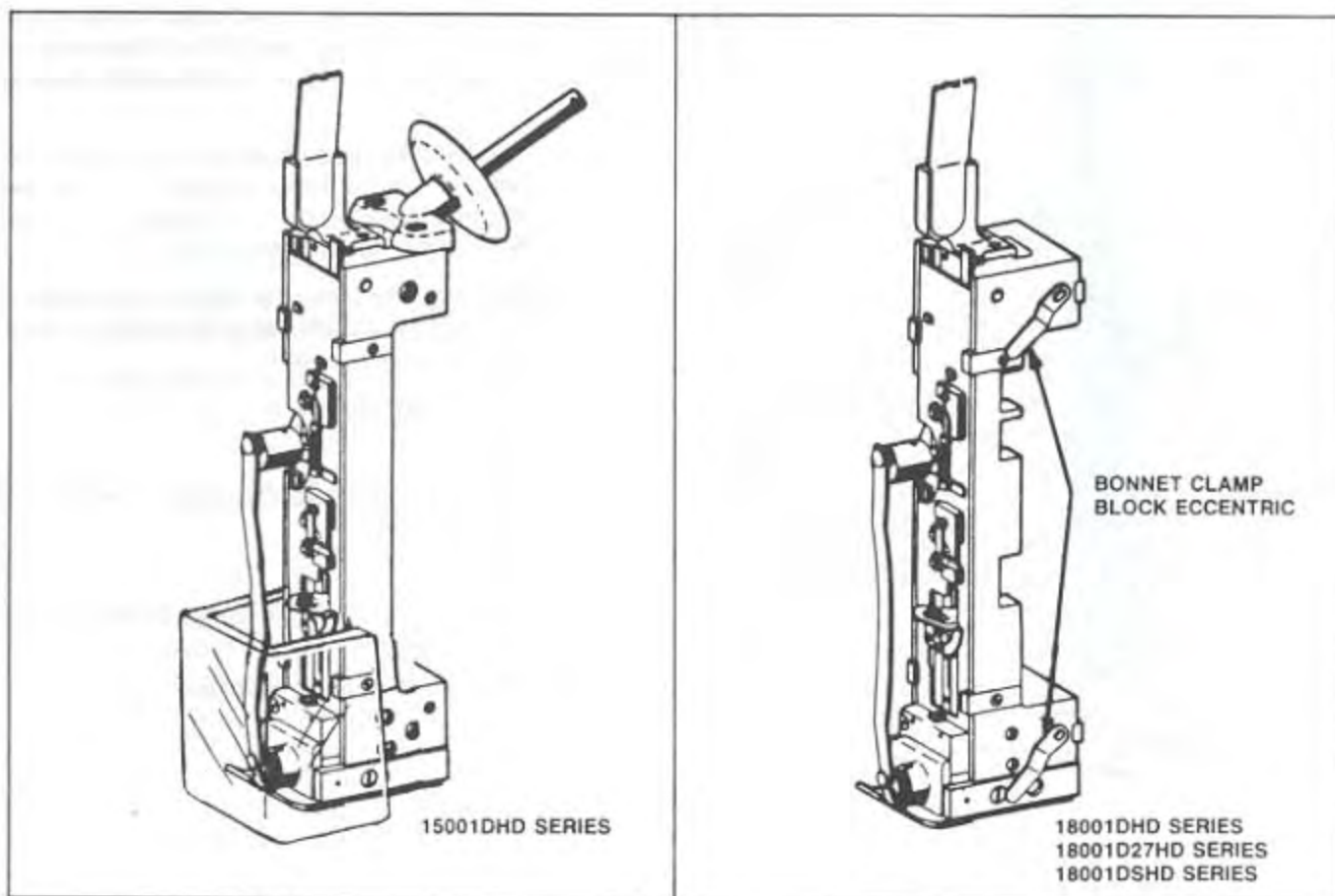

FIGURE 1
Variation Between Heads

OPERATING ADJUSTMENTS

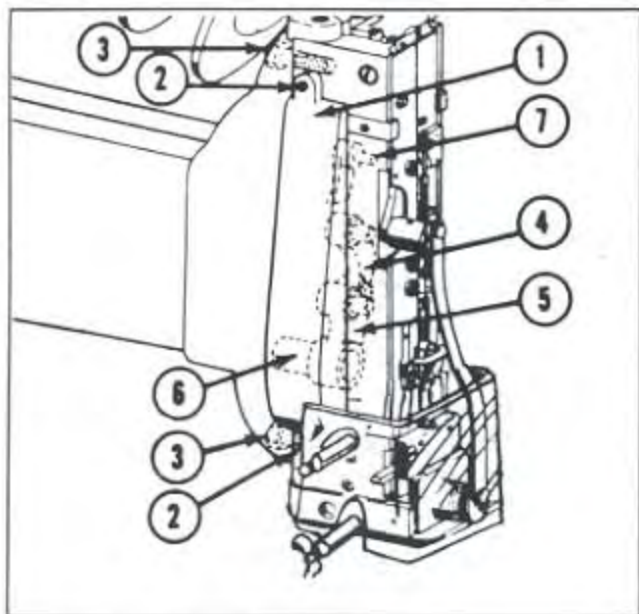

FIGURE 2
Removing and Attaching
15001DHD Series Heads

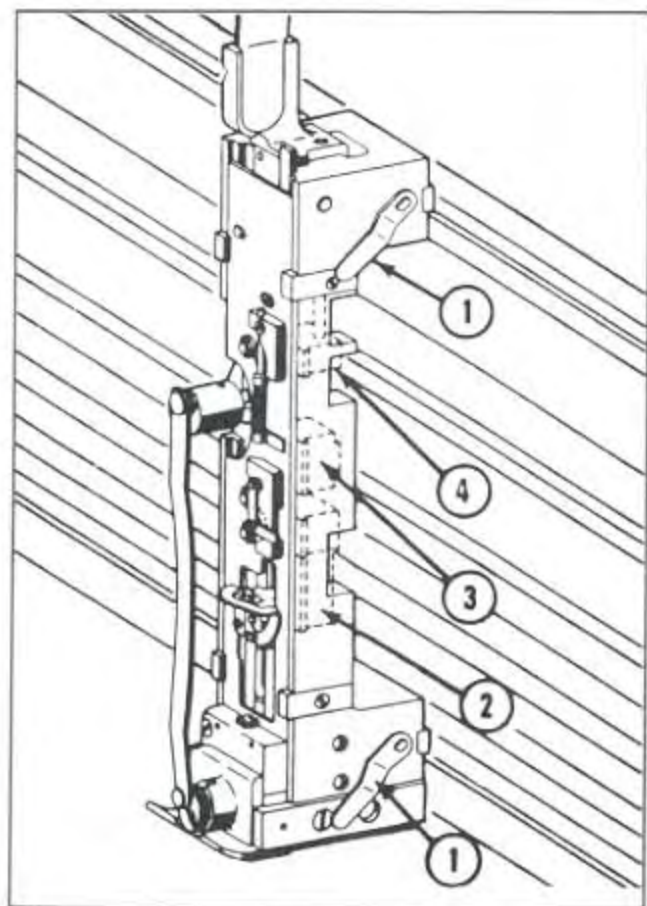

FIGURE 3
Removing and Attaching
18001DHD Series or 18001D27HD Series Heads

The quality and quantity of work which a Bostitch stitcher head can produce are dependent upon the operator's making the various adjustments as accurately as possible. The following illustrated instructions are provided so that the operator will understand clearly how to make these adjustments.

WARNING: TURN ELECTRICAL SWITCH "OFF" BEFORE REMOVING OR SERVICING HEADS.

1. REMOVING 15001DHD SERIES HEADS:

(See Fig. 2)

- a) Remove the spool of wire.
- b) Remove the guards (1) and the upper and lower screws (2).
- c) Remove the bonnet screws (3).
- d) Pull the head off the machine, at the same time removing the driver link (4) and the bender link (5).

2. ATTACHING 15001DHD SERIES HEADS:

(See Fig. 2)

- a) Attach the links (4 and 5) to the driving slide block and the bender slide, locate the crank pin (6) in the bender link (5), and the adjusting link pin (7) in the hole in the face plate adjusting slide.
- b) Hold the head just far enough away from the frame to see the holes in which to insert the bonnet screws (3); then assemble and tighten the screws. Replace the guard.
- c) Make sure the screws are tight before starting the machine. Rotate the drive pulley by hand before applying power.
- d) Attach Head Guard.

3. REMOVING 18001DHD OR 18001D27HD SERIES HEADS:

(See Fig. 3)

- a) Unclamp the upper and lower bonnet clamp block eccentrics (1).
- b) Pull the head off the machine.

4. ATTACHING 18001DHD SERIES OR 18001D27HD SERIES HEADS:

(See Fig. 3)

- a) Engage the bender slide (2), the driving slide (3), and the face plate adjusting slide (4) with the corresponding rails.
- b) Clamp the head to the machine by pressing down on the upper and lower bonnet clamp block eccentrics (1).

5. THREADING WIRE:

(See Fig. 4)

- a) Place a spool of wire on the spool stud so that the wire will pull from under the left side.
- b) Disengage the swivel operating spring (1) from the swivel (2) by lifting the lower end of the spring and swinging it to the left.
- c) Run the wire over the wire guide spring (3), and thread it between the wire guide spring studs (4), under the flanges of the wire straightener rolls (5), thru oiler felt in retainer (not shown) and then between the face plate wire straightener rolls (6).
- d) Open the wire straightener eccentric by lowering the handle to the bottom notch in the block. Feed the wire down through the face plate straightener rolls (7) and the wire straightener eccentric roll (8).
- e) Pull the wire down until any crooked wire has passed through the rolls.
- f) Pass the wire through the grip holder (9); then cut it off just below the grip holder, and insert about 1/4 (6.4mm) inch of wire into the slot on the top of the stationary wire cutter (10).
- g) Replace the swivel operating spring. The wire can now be cut off by starting the machine.

6. STRAIGHTENING WIRE:

(See Fig. 5)

- a) Adjust the wire straightener eccentric (1).
- b) Determine the correct location of the eccentric by disengaging the swivel operating spring (2) and removing the swivel (3), and watch the wire as it is fed past the opening in the swivel holder when the machine is operated. If the wire curls to the left, the straightener is not set tight enough. If the wire curls to the right, the straightener is set too tight.

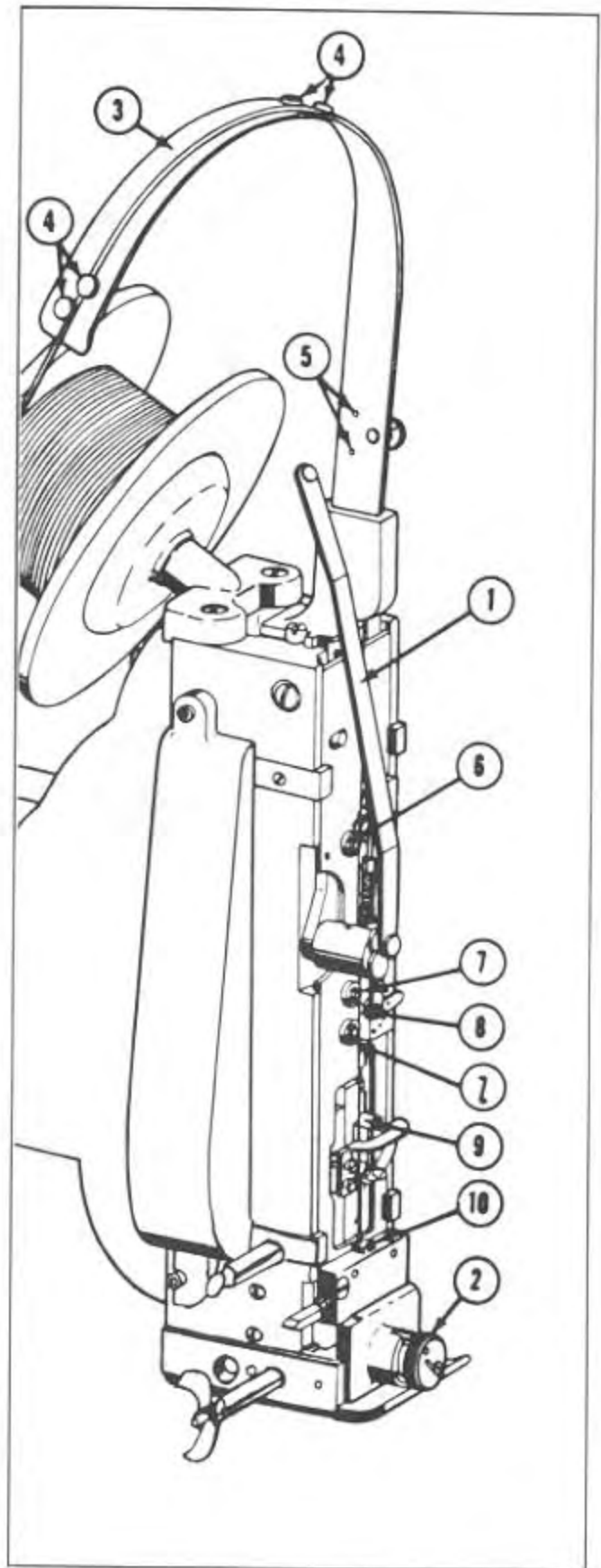

FIGURE 4
Threading Wire

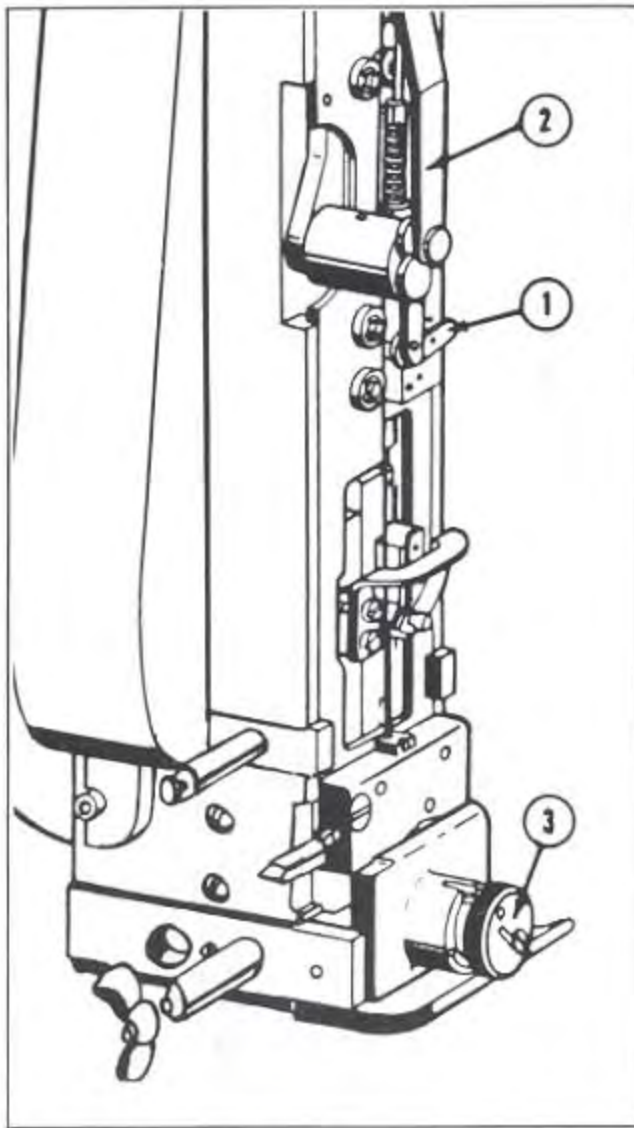

FIGURE 5
Straightening Wire

- c) Check the straightness of the wire each time a new coil is installed on the machine, or if the wire fails to feed properly into the swivel.

7. ADJUSTING LENGTH OF STAPLES:

(See Fig. 6)

- a) To change the length of both legs of the staple, loosen the face plate adjusting screw (1) and push the face plate (2) up to lengthen, or down to shorten, the legs of the staple. Tighten the screw (1) after adjusting.

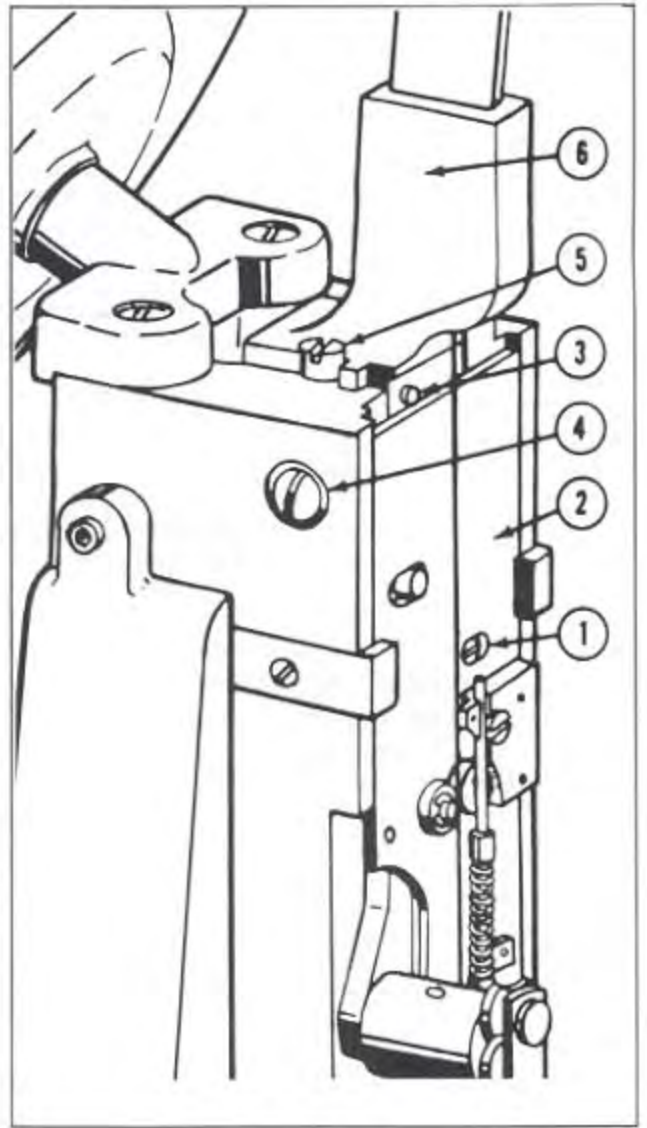

FIGURE 6
Adjusting Length of Staples

- b) To increase the left leg of a staple, loosen the wire guide spring bracket adjusting screw (5) and the wire guide spring bracket screw (4), then turn the wire guide spring bracket adjusting screw (5) counterclockwise. Press down firmly on the wire guide spring bracket (6) until the bottom of the head of the adjusting screw (5) bears against the top of the bonnet casting. Tighten the binder screw (3) and the screw (4). A quarter turn of the adjusting screw makes a considerable difference in the length of the leg. Turn the adjusting screw clockwise to shorten the leg.

MAINTENANCE

To insure continuous operation, the operator should be certain that the heads are lubricated regularly and maintained carefully. The operator should periodically inspect all moving parts for signs of wear and, when required, replace the worn parts. Such parts as the wire cutters, grips, and drivers are subject to wear and have been designed to provide duplicate cutting or gripping surfaces. If, after continuous usage, the original cutting or gripping surface of any such part shows signs of wear, the position of the part can be reversed so that a new surface is provided and the life of the part is lengthened.

1. LUBRICATION:

(See Fig. 7)

NOTE: Before using the head, lubricate it sparingly to prevent oil from gathering at the bottom of the head and soiling the work. Use oil equivalent to SAE 10.

- a) Place a few drops of oil on top of the head at each side of the wire guide spring bracket (1).
- b) Oil the swivel operating lever (2).
- c) Oil the driver bar and the bender bar through the top of the large opening at the bottom of the face plate (3).
- d) Oil the angular slot in the wire cutter operating slide (4) where it shows at the left of the opening in the face plate.
- e) Put a drop of oil on the swivel (5).
- f) Apply a few drops of oil to the staple wire biler felt (not shown).

2. REMOVING SLIDING WIRE CUTTER:

(See Fig. 8)

- a) Before removing the sliding wire cutter (1), rotate the pulley by hand and trip the machine once so that the moving parts of the head stop at the top of the stroke.
- b) Loosen the wire cutter slide screw (3) to disengage from the wire cutter slide (4), and at the same time, push upward on the wire cutter slide pin (5) until it contacts the top of the clearance cut provided for it in the face plate.
- c) Then slide out the wire cutter (1).

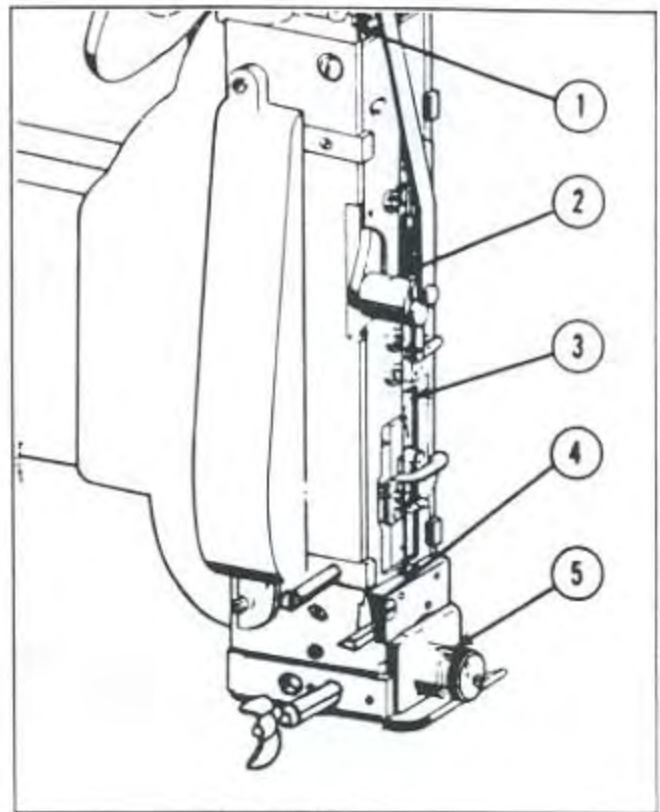

FIGURE 7
Points of Lubrication

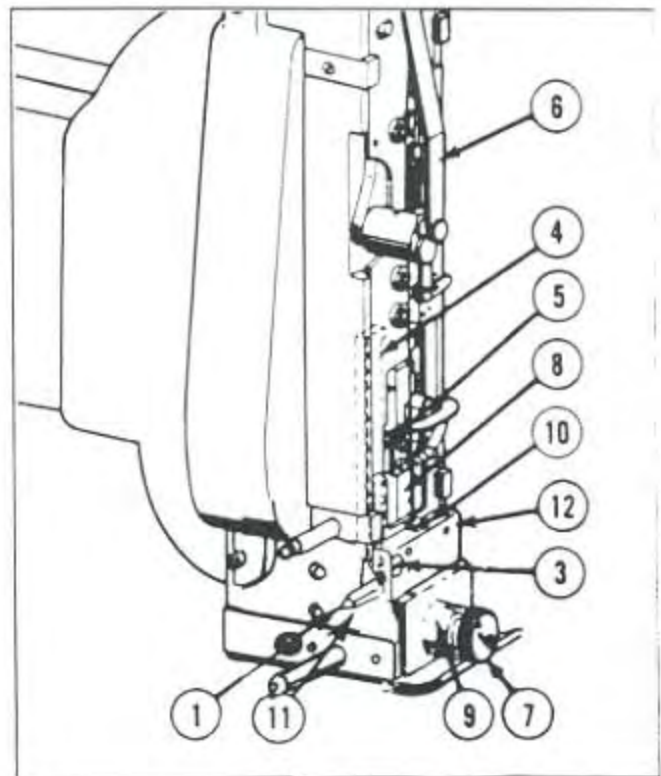

FIGURE 8
Removing and Replacing Wire Cutters

3. REPLACING SLIDING WIRE CUTTER:

(See Fig. 8)

NOTE: The sliding wire cutter may be reversed if one cutting edge becomes dull or worn.

- a) If the wire cutter slide screw (3) has re-engaged the slot in wire cutter slide (4) while the sliding wire cutter is out of the head, repeat the steps in paragraph 2 to disengage the screw from the slide.
- b) Disengage the swivel operating spring (6) from the swivel (7) by lifting the lower end of the spring and swinging it to the left; then remove the swivel.
- c) Trip the machine and rotate the pulley until the bottom end of the driver (8) appears at the top of the opening in the swivel holder (9).
- d) Place the sliding wire cutter (1) in the slot provided for it, and with the tongue of the cutter toward the back of the machine, push down on the wire cutter slide pin (5) until the tongue is engaged by the slot in the wire cutter slide (4). Turn wire cutter slide screw (3) clockwise to engage slot in wire cutter slide and tighten.
- e) Replace the swivel (7) and the swivel operating spring (6).

4. REMOVING STATIONARY WIRE CUTTER:

(See Fig. 8)

- a) Before attempting to remove the stationary wire cutter (10), loosen the stationary wire cutter binder screw (11).
- b) Grasp the cutter with pliers and pull up.
- c) If the stationary wire cutter has been shortened from successive grindings so that it does not extend far enough above the wire cutter holder (12) to be grasped, remove the swivel (7) and the sliding wire cutter (1) and drive the stationary wire cutter down and out.

5. REPLACING STATIONARY WIRE CUTTER:

(See Fig. 8)

NOTE: The stationary wire cutter may be reversed for any wire size other than ribbon wire.

- a) Replace the sliding wire cutter and rotate the pulley until the cutter is in the cut-off position.
- b) Place the cutter (10) in the wire cutter holder (12), and press the stationary wire cutter down firmly against the sliding wire cutter (1) while tightening the stationary wire cutter binder screw (11).

6. REMOVING GRIP:

(See Fig. 9)

- a) To gain access to the grip (1), lift the lower end of the swivel operating spring (2) from the swivel (3), and swing it to the left.
- b) Loosen the grip spring (4) and the grip block (5) by removing the lower grip block screw (6) and loosening the upper grip block screw (7). Swing the grip spring and the grip block aside.
- c) Pull the grip retaining spring (8) forward to clear the locking pin, and swing the spring to the left.
- d) Pull the grip holder (9) off the stud (10).
- e) Remove the grip retaining spring, and remove the grip.

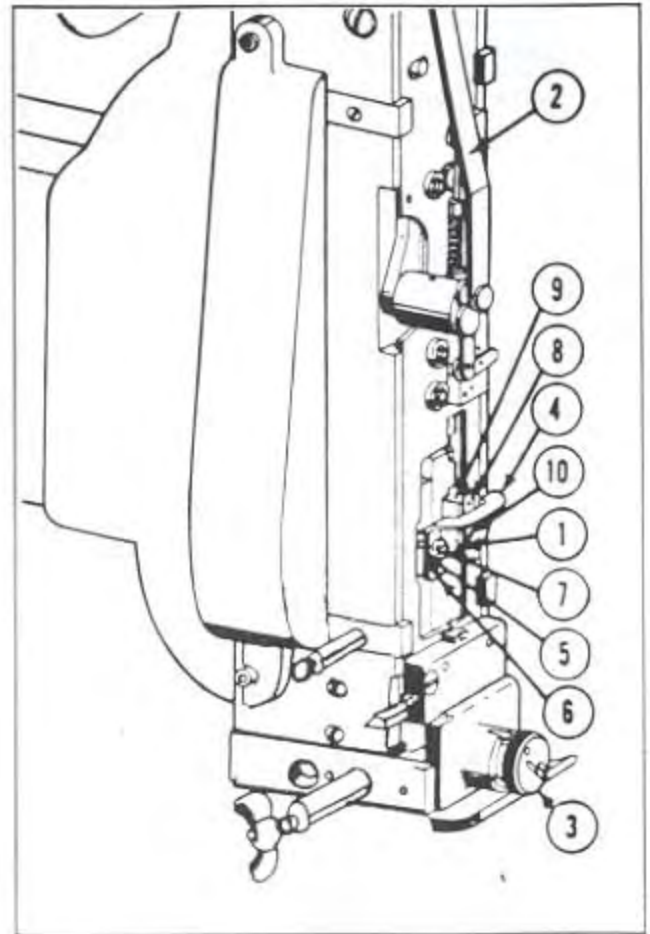

FIGURE 9
Removing and Replacing Grip

7. REPLACING GRIP:

(See Fig. 9)

NOTE: The grip for ribbon and hybar wire has four contact surfaces, and need not be replaced until all four surfaces are worn.

- a) Replace the grip in the grip holder (9).
- b) Return the grip holder to the stud (10).
- c) Return the grip retaining spring (8), and secure it under the locking pin.
- d) Fasten the grip block (5) and the grip spring (4) by tightening the upper grip block screw (7) and replacing the lower grip block screw (6). Be sure that the end of the spring is engaged behind the head of the stud on the grip holder.
- e) Replace the swivel (3) and the swivel operating spring (2).

8. REMOVING DRIVER:

(See Fig. 10)

NOTE: The driver is double-ended and may be reversed.

- a) Before removing the driver (1), rotate the drive pulley until the driver is at the upper end of its stroke.
- b) Remove the swivel (2), insert the driver release pin (3) into the hole in the driver, and push in and down.
- c) Withdraw the driver through the underside of the head.

9. REPLACING DRIVER:

(See Fig. 10)

- a) Rotate the driver pulley until the end of the bender bar (4) can be seen through the opening in the swivel holder (5).
- b) Insert the end of the driver into the grooves in the bender bar, and push the driver up until it engages the catch.

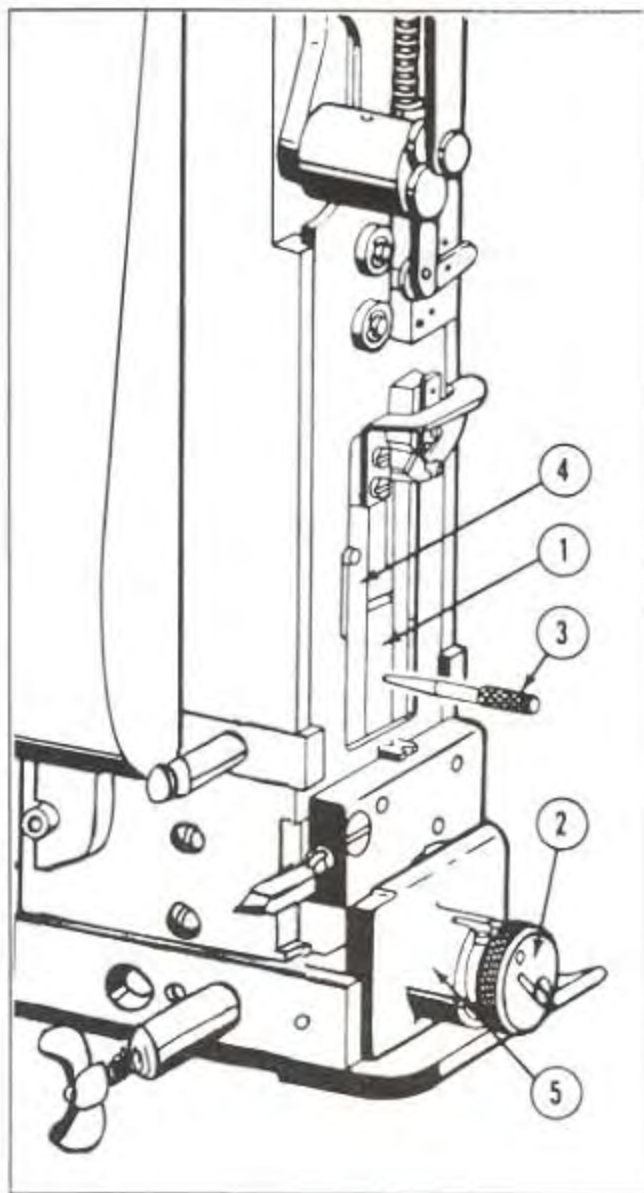

FIGURE 10
Removing and Replacing Driver

DISASSEMBLY AND REASSEMBLY

1. DISASSEMBLING HEAD:

(See Fig. 11)

- a) After removing the head from the stitching machine, remove the swivel operating spring (1) by swinging it to the right and upward until it can be disengaged from the stud.
- b) Remove the swivel (2).
- c) Remove the swivel holder (3) by removing the swivel holder clamp screw (4) and the swivel holder clamp (5).
- d) Remove the face plate (6) by backing out the four face plate clip screws (7) until the face plate clips (8) can be moved out to release the face plate.
- e) Recover the sliding wire cutter (9).
- f) Remove the wire cutter slide (10), the grip release slide (11), and the grip release lever (12).
- g) Remove the wire guide spring bracket screw (13). Push the wire guide spring bracket (14) upward and out of the head, tapping it if necessary. Remove the face plate adjusting slide (15).
- h) Swing the swivel operating lever (16) to the left, and remove the entire assembly of forming and driving parts by sliding them upward and out of the head.
- i) Remove the driving slide assembly (17) by sliding it to the right or to the left.
- j) Remove the bender slide (18) by working it off backward from the bender bar (20). (The tension of the supporter spring is against the bottom of the slide).
- k) Disengage the end of the grip spring (21) from the stud on the grip holder (22), and slide the driver bar (23) and the driver (24) downward and out of the bender bar (20).
- l) Remove the supporter (25) by driving the supporter pivot pin (26) to the left and out.
- m) If necessary, remove the swivel operating lever (16) by removing the swivel operating lever stud screw (27) and lock washer (28) from the back of the swivel operating lever stud (29) and driving the stud out from the back of the head.

2. REASSEMBLING HEAD:

(See Fig. 11)

- a) Attach the following parts to the bender bar (20) if previously removed: the supporter (25) and supporter pivot pin (26); the grip, grip holder (22), grip retaining spring, grip block, grip spring (21), and grip block screws; and the driver (24), driver bar (23), supporter spring, and supporter spring plunger.
- b) Engage the bender slide (18) with the bender bar (20) by pushing down on the supporter spring plunger and entering the bender slide connection pin into the groove at the upper end of the bender bar.
- c) Push these assembled units into the head. Allow enough of the bender slide (18) to protrude to permit the lower end of the driving slide (17) to be engaged with the groove in the driver bar (23); then attach the driving slide.
- d) If previously removed, replace the swivel operating lever (16), hub, stud (29), washer (28), and lever stud screw (27). Push the parts assembled in paragraph b down into the head until the swivel operating lever can be swung to the right and its upper arm can contact the swivel operating pin at the upper part of the driving slide (17).
- e) Put the face plate adjusting slide (15) and the wire guide spring bracket (14), assembled together, into the grooves in the top of the head. Press down firmly until the bottom of the head of the wire guide spring bracket adjusting screw bears against the top of the bonnet casting.
- f) Replace the wire guide spring bracket screw (13).
- g) Push back on the supporter (25), so that the supporter guide pin will clear the supporter guide plate, and at the same time slide the driver and bender assembly down until the end of the bender bar is about one inch from the bottom of the head. Replace the wire cutter operating slide (10).
- h) Install the grip release lever (12) with the pin at the left facing out. Replace the grip release slide (11) with the slot over the lever.

(Continued page 12)

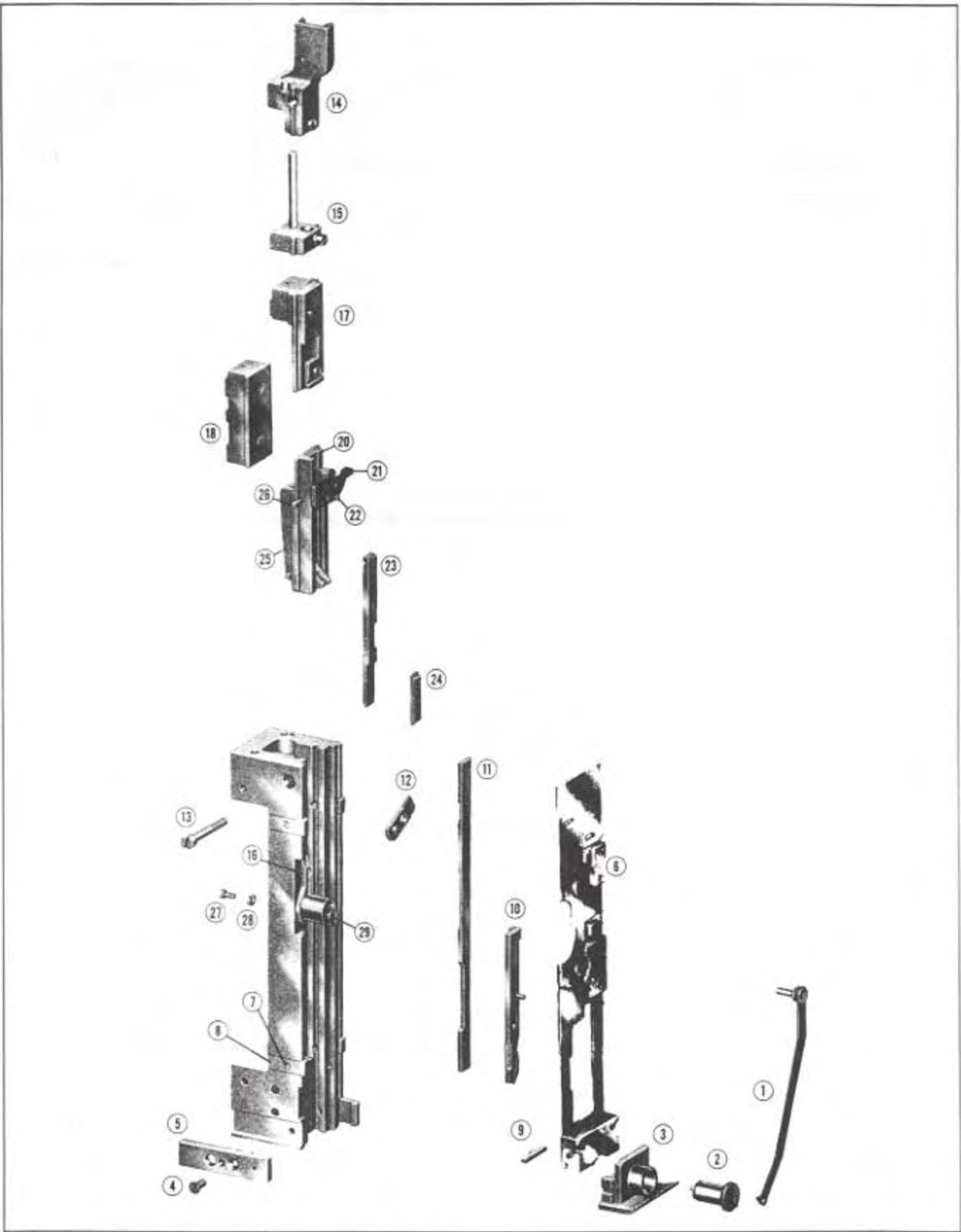

FIGURE 11
Disassembled Head

REASSEMBLING HEAD

(Cont'd)

- i) Put the face plate in position on the head. Line up the face plate adjusting screw and the stud on the grip release lever (12) with the holes in the face plate. Make sure that the pin in the wire cutter operating slide (10) is clear of the face plate.
- j) Replace the face plate clip (8), and tighten the screws (7).
- k) Attach the swivel holder (3), and press it tightly against the cutter holder on the face plate. Tighten the left-hand clamp (5), and engage the left side of the swivel holder in this clamp, tapping if necessary. Engage the right-hand clamp, forcing the side of the swivel holder down until the screw holes in the clamp and in the head are aligned. Insert and tighten the screw (4).
- l) Replace the sliding wire cutter (9) (see paragraph 3 of the Maintenance Section).
- m) Replace swivel (2) and swivel operating spring (1).

SPECIAL NOTE

Point of operation guards are available for all heads described herein.
Refer to appropriate stitcher operation and maintenance manual.

TROUBLE SHOOTING





The quality and quantity of work that can be produced with the Bostitch Stitcher Heads are dependent upon the operator making all adjustments as accurately as possible, and carefully maintaining the heads. The cause of staple imperfections may be usually traced to inaccurate settings or adjustments, or normal wear of moving parts. In the event that trouble of this nature may occur, the operator can, by referring to the following Trouble Shooting Chart, quickly locate and remedy the causes of the trouble, thereby reducing to a minimum the time the stitcher is inoperative.

The first column of the chart illustrates perfect and imperfect stitches; the second column describes the









imperfections (troubles); the third column lists the probable cause, or causes, for the given trouble; the fourth column lists the remedy, or remedies, for the troubles and also refers to the paragraph in this book in which will be found detailed information and instructions for making the necessary adjustments.

If stitching is defective, the operator can compare the stitch produced with the stitches illustrated in the chart and, by carefully reading the information given for each type of imperfect stitch, remedy the cause of the imperfection.



















TROUBLE SHOOTING CHART FORMED STAPLES

<i>Staple</i>	<i>Trouble</i>	<i>Cause</i>	<i>Remedy</i>
	Perfect staple	—	—
	Right leg short	Cutter not properly adjusted in relation to swivel	Shorten left leg to same length as right leg; adjust length of both legs to desired length (see paragraph 7, page 6).
	Left leg short	Wire feed not adjusted properly	Adjust length of left leg (see paragraph 7, page 6).
		Worn grip	Reverse or replace grip (see paragraphs 6 and 7, pages 8 and 9).
		Weak grip spring	Replace grip spring.
	Staple corner buckles	Chipped or broken driver	Check driver for signs of damage; reverse or replace driver (see paragraphs 8 and 9, page 9).

TROUBLE SHOOTING FORMED STAPLES

<i>Staple</i>	<i>Trouble</i>	<i>Cause</i>	<i>Remedy</i>
	Either or both legs buckled	Wire too small	Check wire size for job being done.
		Dull wire cutters	Reverse or replace wire cutters (see paragraphs 2, 3, 4, and 5, pages 7 and 8).
	Bent crown	Wrong size wire	Check wire size.
		Insufficient compression	Adjust compression.
		Supporter retracts too easily	Replace supporter spring.
	Left leg missing	Wire slipping in grip	Change grip to new surface or replace grip (see paragraphs 6 and 7, pages 8 and 9).
		Weak grip spring	Replace grip spring.
	Right leg missing	Corner of swivel too sharp	Slightly stone the corner of swivel over which wire is formed.
	Corner broken or nearly cut through	Corner of swivel too sharp	Slightly stone the corner of swivel over which wire is formed.
		Swivel hook spring too weak	Replace swivel hook spring.
		Wire too brittle	Change wire.
	Staple comes out in pieces	Swivel sticking	Clean and lubricate swivel.
		Corner of swivel too sharp	Slightly stone the corner of swivel over which wire is formed.
		Swivel hook spring too weak	Replace swivel hook spring.
	Corners rounded	Worn swivel	Replace swivel.
	Staple leg turned	Dull cutters	Reverse or replace either cutter. Sliding wire cutter may be reversed. Stationary wire cutter is reversible for any wire except ribbon wire. Stationary wire cutter may be ground if cutting edge becomes dull.

TROUBLE SHOOTING DRIVEN AND CLINCHED STAPLES

Staple		Trouble	Cause	Remedy
Solid Clincher	Movable Clincher			
		Perfect Stitch	—	—
		Legs uneven	Cutter not properly adjusted in relation to swivel	Shorten left leg to same length as right leg; adjust length of both legs to desired length (see paragraph 7, page 6).
			Wire feed not properly adjusted	Adjust length of left leg (see paragraph 7, page 6).
			Worn grip	Reverse or replace grip (see paragraphs 6 and 7, pages 8 and 9).
			Weak grip spring	Replace grip spring.
		Loose clinch	Clincher set too low	Set clincher higher.
		Legs spread	Wire straightener not properly adjusted	Check setting of wire straightener (see paragraph 6, page 5).
			Worn bender bar	Replace bender bar.
		Only one leg clinches	—	—
		One leg buckles	Clincher not in line with driver	Align clincher.
		Legs clinch unevenly	—	—
		Short legs	Insufficient wire draw	Adjust length of both legs.
		Uneven clinching	Clincher not level and parallel to bender bar	Make clincher level and parallel to bender bar.

REPAIR PARTS

WHEN ORDERING REPLACEMENT PARTS BE SURE TO SPECIFY PART NUMBER, MACHINE MODEL AND SERIAL NUMBERS. USE ONLY GENUINE BOSTITCH PARTS FOR SATISFACTORY SERVICE.

1. EXPLANATION OF THE PARTS LIST:

The illustrations and parts list included in the following pages are provided to expedite the ordering of repair parts for the 15001DHD series, 18001DHD series and 18001D27HD series heads.

As previously explained, the heads are basically similar. However, variations occur in some of the component parts because the basic head is adapted to both the single stitch and gang stitch machines.

The following parts list and accompanying exploded views of the heads, Figure 12, identify all the parts contained in these heads. In Figure 12, all parts that are used in the 15001DHD series heads (most of which are common to the other heads) are illustrated; those parts that are used only in the 18001DHD series or 18001D27HD series heads are shown in solid outline; and those parts that are used only on the 18001DHD series heads are shown in broken outline.

The parts in Figure 12 are identified by index numbers that are listed numerically in the first column of the accompanying parts list.

NOTE: Do not confuse the index numbers with the part numbers; when ordering parts, order the required part by part number and not by index number.

The second column of the parts list gives the name of each part, while the third column, subdivided into

separate columns, gives the part number of each part according to the head on which it is used.

It will be noted that in the second column certain part names are indented. This indentation indicates that these parts, together with the immediately preceding part that is not indented, make up an assembly. If the part number of the non-indented part is ordered, it will be shipped assembled with the indented parts. However, any of the indented parts may be purchased separately if desired.

NOTE: Those parts designated by an asterisk (*) preceding the name of the part should be installed by a Bostitch service man.

2. IDENTIFYING AND ORDERING A PART:

- a) Locate the required part in Figure 12, and note the index number identifying the part.
- b) In the first column of the accompanying parts list, locate the part index number.
- c) From the PART NUMBER column (for the specific head in which the part is used) select the part number listed for the particular part or assembly.
- d) Order the part by specifying the PART NUMBER and, if noted in the NAME column, the size of wire to which the part must conform.

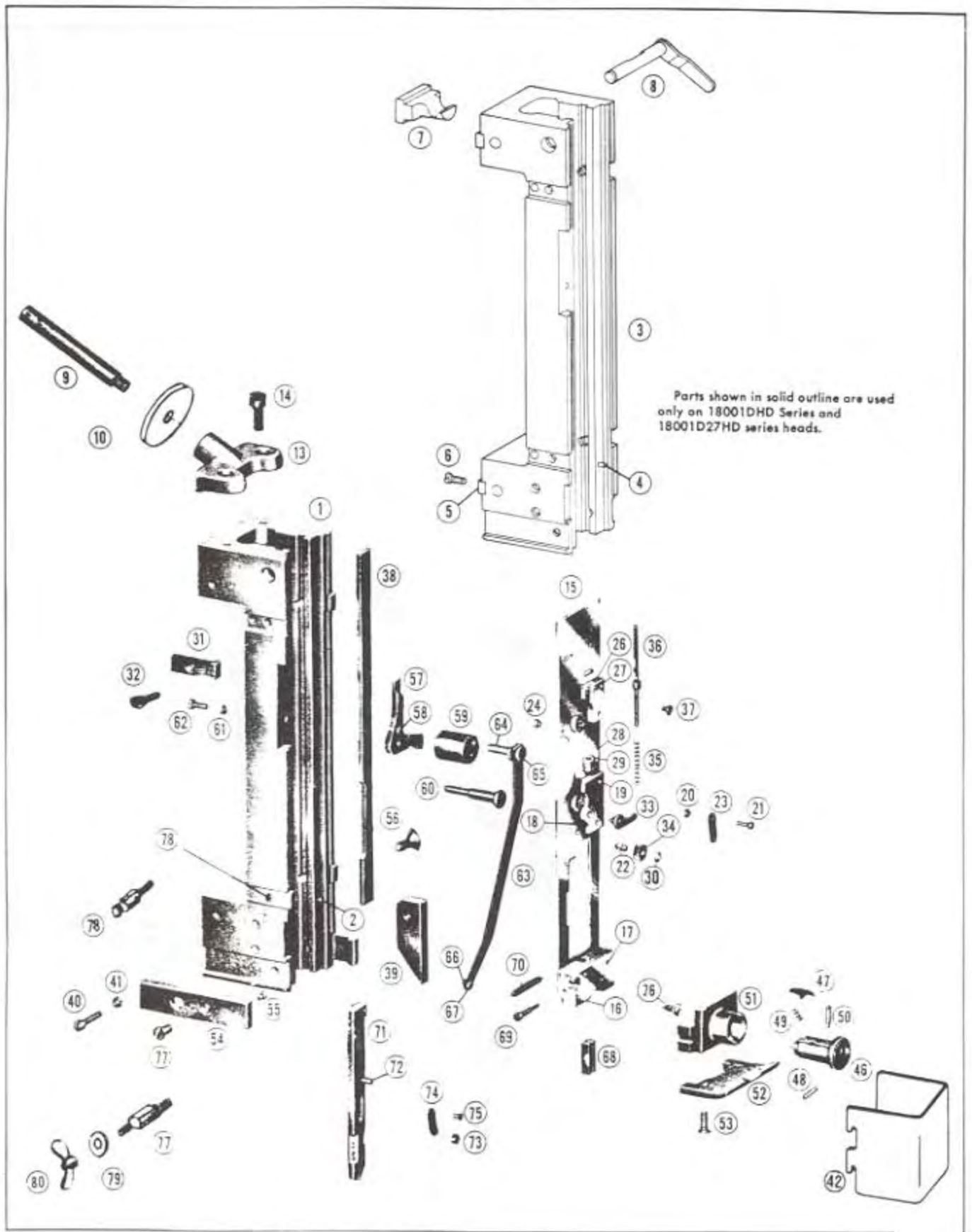

FIGURE 12 (Sheet 1)
Head Component Parts

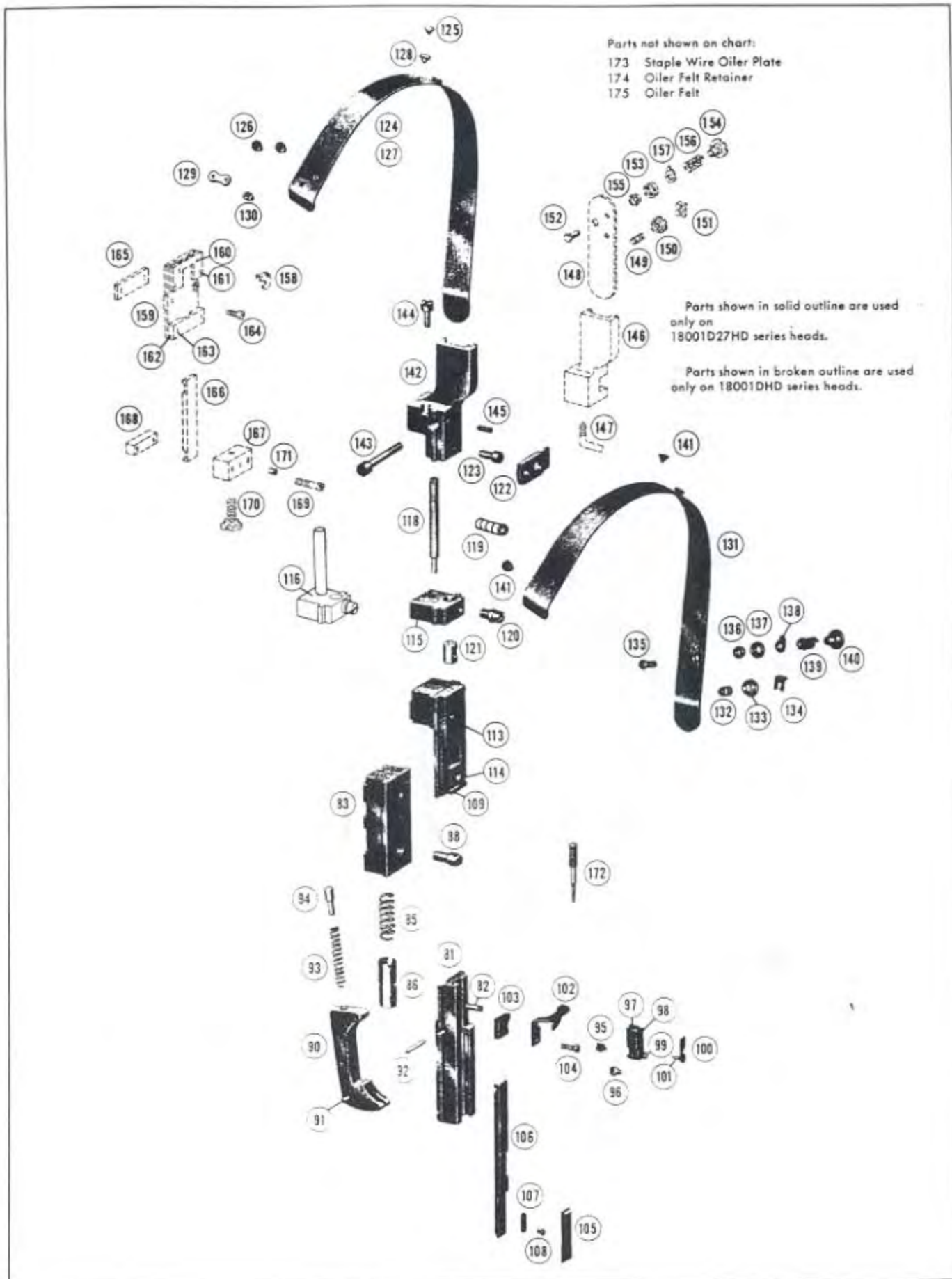

FIGURE 12 (Sheet 2)
 Head Component Parts

PARTS LIST

Items 1-80 are shown on sheet 1

Index #	Name and Description	Part Number			
		15001DHD SERIES	18001DHD SERIES	18001D27HD SERIES	18001DSHD SERIES
1	Bonnet, 1/2 (12.7mm)	15001BA	—	—	—
	Bonnet, 3/4 (19.1mm)	15001BA-3/4	—	—	—
2	Grip Release Slide Stop Pin	UB3108.1	—	—	—
3	Bonnet, 1/2 (12.7mm)	—	18001BA	18001BA	18001BA
	Bonnet, 5/8 (15.9mm)	—	—	—	18001BA-3/4
	Bonnet, 3/4 (19.1mm)	—	—	—	18001BA-3/4
4	Grip Release Slide Stop Pin	—	UB3108.1	UB3108.1	UB3108.1
5	Bonnet Key	—	18002	18002	18002
6	Bonnet Key Screw	—	110	110	110
7	Bonnet Clamp Block	—	9002	9002	9002
8	Bonnet Clamp Block Eccentric	—	18005A	18005A	18005A
9	Spool Stud	7155	—	—	—
10	Spool Stud Washer	2245	—	—	—
13	Spool Stud Bracket	15161	—	—	—
14	Spool Stud Bracket Screw	UA5812.11	—	—	—
15	Face Plate — see Page 22 for Part Numbers				
16	Wire Cutter Holder, 1/2 (12.7mm)	15105E	15105E	15105E	15105E
16	Wire Cutter Holder, 3/4 (19.1mm)	15605B	—	—	15605B
17	Wire Cutter Holder Rivet, 5/8 (15.9mm)	15106	15106	15106	15106
	Wire Cutter Holder Rivet, 3/4 (19.1mm)	—	—	—	15106
18	Wire Str. Eccentric Block—Ribbon and Hybar Wire	15130	19130	15130	—
18	Wire Str. Eccentric Block—Flat and Round Bookbinders Wire	19130	19130	19130	19130
19	Wire Str. Eccentric Block Rivet	11057	11057	11057	11057
20	Wire Str. Eccentric Clip Spacer	19133	19133	19133	19133
21	Wire Str. Eccentric Clip Rivet	19134	19134	19134	19134
22	Wire Str. Roll Stud	19122B	19122B	19122B	19122B
23	Wire Str. Eccentric Clip	15123	15123	15123	15123
24	Swivel Operating Lever Stop Stud	9059	9059	9059	9059
26	Tension Roll Block	15142	19142	19142	19142
27	Tension Roll Block Rivet	257	257	257	257
28	Tension Pawl Spring Rod Guide	19148	19148	19148	19148
29	Tension Pawl Spring Rod Guide Rivet	9055	9055	9055	9055
30	Wire Str. Roll Retainer	85018	85018	85018	85018
31	Face Plate Clip	15092B	15092B	15092B	15092B
32	Face Plate Clip Screw	UA3808.9	UA3808.9	UA3808.9	UA3408.1
33	Wire Str. Eccentric	19128A	19128A	19128A	19128A
34	Wire Str. Roll (For Wire Under .030 (.76mm) Thick	19121	19121	19121	19121
34	Wire Str. Roll (For Wire .030 (.76mm) Thick and Over)	19121B	—	—	—
35	Tension Roll Spring	7180	7180	7180	7180
36	Tension Roll Spring Rod	19147A	19147A	19147A	19147A
37	Tension Roll Spring Rod Retainer	5062	5062	5062	5062
38	Grip Release Slide, 1/2 (12.7mm)	15045	15045	15045	15045
	Grip Release Slide, 5/8 (15.9mm)	—	—	—	15645
	Grip Release Slide, 3/4 (19.1mm)	15645	—	—	—
39	Supporter Guide Plate, 1/2 (12.7mm)	15061	15061	15061	15061
	Supporter Guide Plate, 5/8 (15.9mm)	—	—	—	15661
	Supporter Guide Plate, 3/4 (19.1mm)	15661	—	—	—
40	Supporter Guide Plate Screw	UA3214.1	UA3214.1	UA3214.1	UA3214.1
41	Supporter Guide Plate Screw Lock Washer	LW10.4	LW10.4	LW10.4	LW10.4
42	Head Guard	14596	—	—	—
46	Swivel — see Page 22 for Part Numbers				
47	Swivel Hook (Flat and Round Bookbinder's, and Hybar Wire)	7232	7232	7232	7232
	Swivel Hook (Ribbon Wire)	15071	—	—	—
48	Swivel Hook Pin	7233	7233	7233	7233
49	Swivel Hook Spring	7234	7234	7234	7234
	Swivel Hook Spring (Ribbon Wire)	15060	—	—	—
50	Swivel Safety Pin	UB3808.3	UB3808.3	UB3808.3	15069
51	Swivel Holder	15072B	15072B	15072B	15072B
52	Swivel Holder Guard	15076	15076	15076	15076
53	Swivel Holder Guard Screw	UA3410.1	UA3410.1	UA3410.1	UA3410.1
54	Swivel Holder Clamp	15073A	15073A	15073A	15073A

PARTS LIST (continued)

Index #	Name and Description	Part Number			
		15001DHD SERIES	18001DHD SERIES	18001D27HD SERIES	18001DSHD SERIES
55	Swivel Holder Dowel.....	15075	15075	15075	15075
56	Swivel Holder Clamp Screw — Right Side.....	9044	9044	9044	9044
57	Swivel Operating Lever.....	19078A	19078A	19078A	19078A
58	Swivel Operating Lever Pin.....	19080	19080	19080	19080
59	Swivel Operating Lever Hub.....	19081	19081	19081	19081
60	Swivel Operating Lever Stud.....	19079	19079	19079	19079
61	Swivel Operating Lever Stud Screw Lock Washer.....	LW10.4	LW10.4	LW10.4	LW10.4
62	Swivel Operating Lever Stud Screw.....	9057	9057	9057	9057
63	Swivel Operating Spring.....	19084A	19084A	19084A	19084A
64	Swivel Operating Spring Stud.....	19085	19085	19085	19085
65	Swivel Operating Spring Stud Washer.....	15086	15086	15086	15086
66	Swivel Operating Spring Pin.....	15087	15087	15087	15087
67	Swivel Operating Spring Pin Washer.....	9140	9140	9140	9140
68	Stationary Wire Cutter—see Page 22 for Part Numbers				
69	Stationary Wire Cutter Binder Screw.....	15102	15102	15102	15102
70	Sliding Wire Cutter 1/2 (12.7mm).....	15104	15104	15104	15104
71	Wire Cutter Slide, 1/2 (12.7mm).....	15113A	15113A	15113A	15113A
	Wire Cutter Slide, 5/8 (15.9mm).....	—	—	—	15613BA
	Wire Cutter Slide, 3/4 (19.1mm).....	15613BA	—	—	—
72	Wire Cutter Slide Pin.....	15118	15118	15118	15118
73	Wire Cutter Slide Friction.....	15116B	15116B	15116B	15116B
74	Wire Cutter Slide Friction Spring.....	7224	7224	7224	7224
75	Wire Cutter Slide Friction Spring Rivet.....	5037B	5037B	5037B	5037B
76	Wire Cutter Slide Catch Screw.....	15110	15110	15110	15110
77	Swivel Holder Clamp Screw — Left Side.....	14598	9044	9044	—
78	Face Plate Clip Screw — Bot. Left.....	14597	UA3808.9	UA3808.9	—
79	Head Guard Washer.....	PW10	—	—	—
80	Wing Nut.....	WN1420	—	—	—
<i>The following parts are shown on Sheet 2 of Figure 12.</i>					
81	Bender Bar — see Page 22 for Part Numbers				
82	Grip Holder Stud.....	15033	15033	15033	15033
83	Bender Slide.....	15024	15024	15024	15024
85	Bender Slide Spring.....	15025	15025	15025	15025
86	Bender Slide Spring Plunger.....	15026	15026	15026	15026
88	Bender Slide Connection Pin.....	15027	15027	15027	15027
89	—	—	—	—
90	Supporter, 1/2 (12.7mm).....	15053A	15053A	15053A	15053A
	Supporter, 5/8 (15.9mm).....	—	—	—	15553A
	Supporter, 3/4 (19.1mm).....	15653A	—	—	—
91	Supporter Guide Pin.....	UB3118	UB3118	UB3118	UB3118
92	Supporter Pivot Pin.....	15054	15054	15054	15054
93	Supporter Spring.....	15056	15056	15056	15056
	#25 GA and smaller.....	—	—	—	281
94	Supporter Spring Plunger.....	15057	15057	15057	15057
95	Grip (Ribbon and Hybar Wires).....	15031	—	—	—
96	Grip (Flat and Round Bookbinders Wire).....	19031	19031	19031	19031
97	Grip Holder.....	15032A	15032A	15032A	15032A
98	Grip Retaining Spring Lock Pin.....	UB2106.6	UB2106.6	UB2106.6	15036
99	Grip Spring Retaining Pin.....	15039	15039	15039	15039
100	Grip Retaining Spring.....	15034A	15034A	15034A	15034A
101	Grip Retaining Spring Stud.....	15035	15035	15035	15035
102	Grip Spring.....	15038	15038	15038	15038
103	Grip Block (Ribbon and Hybar Wires).....	15041	—	—	—
	Grip Block (Flat and Round Bookbinders Wire).....	15042	15042	15042	15042
104	Grip Block Screw.....	UA2208.1	UA2208.1	UA2208.1	UA2208.1
105	Driver — see Page 22 for Part Numbers				
106	Driver Bar, 1/2 (12.7mm) (for stitching solid material).....	15015A	15015A	15015A	—
	Driver Bar, 1/2 (12.7mm) (for stitching corrugated material).....	15016A	—	—	—
	Driver Bar, 3/4 (19.1mm) (for stitching solid material).....	15015A	—	—	15015A
	Driver Bar, 3/4 (19.1mm) (for stitching corrugated material).....	15016A	—	—	—
107	Driver Retaining Spring.....	9010	9010	9010	9010
108	Driver Retaining Spring Rivet.....	5037B	5037B	5037B	5037B
109	Driving Slide Assembly.....	19017A	19017A	19017A	19017A

PARTS LIST (continued)

Index #	Name and Description	Part Number			
		15001DHD SERIES	18001DHD SERIES	18001D27HD SERIES	18001DSHD SERIES
113	Driving Slide Swivel Operating Pin	19020	19020	19020	19020
114	Driving Slide Stud	19021	19021	19021	19021
115	Face Plate Adjusting Slide	15097B	15097B	†15097B	15097B
116	Face Plate Adjusting Slide	—	—	27207A	—
118	Face Plate Adjusting Slide Guide Pin	15098	15098	†15098B	15098
119	Face Plate Adjusting Slide Lock Screw	—	—	UA4808.2	—
120	Face Plate Adjusting Screw	15088	15088	†15088	15088
121	Face Plate Adjusting Screw Nut	15089	15089	†15089	15089
122	Grip Release Lever	15046BA	15046BA	15046BA	15046BA
123	Grip Release Lever Pivot	15048	15048	15048	15048
124	Wire Guide Spring (Ribbon and Hybar Wires)	15151A	—	—	—
125	Wire Guide Spring Stud	2110B	—	—	—
126	Wire Guide Spring Stud	15152	—	—	—
127	Wire Guide Spring (Flat and Round Bookbinder's Wire)	—	18150A	—	—
128	Wire Guide Spring Stud	—	2110B	—	—
129	Wire Guide Spring Clip	—	0041	—	—
130	Wire Guide Spring Clip Stud	—	18152	—	—
131	Wire Guide Spring (Flat and Round Bookbinder's Wires)	15150A	—	15150A	9073A
132	Wire Str. Roll Stud	9147	—	9147	9147
133	Wire Str. Roll	9103	—	9103	9103
134	Wire Str. Roll Clip	850699	—	850699	850699
135	Wire Str. Eccentric	9146	—	9146	9146
136	Wire Str. Eccentric Bushing	9068	—	9068	9068
137	Wire Str. Eccentric Roll	9065	—	9065	9065
138	Wire Str. Eccentric Pointer	9070	—	9070	9070
139	Wire Str. Eccentric Spring	9069	—	9069	9069
140	Wire Str. Eccentric Nut	9067	—	9067	9067
141	Wire Guide Spring Stud	2110B	—	2110B	—
142	Wire Guide Spring Bracket	15154	15154	27117D	15154
143	Wire Guide Spring Bracket Screw	15155	15155	15155	15155
144	Wire Guide Spring Bracket Adj. Screw	15156	15156	15156	15156
145	Wire Guide Spring Bracket Adj. Screw Binder	56	56	56	56
146	Wire Guide Spring Holder	—	17288	—	—
147	Wire Guide Spring Holder Screw	—	425	—	—
148	Wire Str. Plate	—	17291A	—	—
149	Wire Str. Roll Stud	—	9147	—	—
150	Wire Str. Roll	—	9103	—	—
151	Wire Str. Roll Clip	—	850699	—	—
152	Wire Str. Eccentric	—	9146	—	—
153	Wire Str. Eccentric Roll	—	9065	—	—
154	Wire Str. Eccentric Nut	—	9067	—	—
155	Wire Str. Eccentric Bushing	—	9068	—	—
156	Wire Str. Eccentric Spring	—	9069	—	—
157	Wire Str. Eccentric Pointer	—	9070	—	—
158	Clincher Point, Flat Wire	—	7024B	—	—
	Clincher Point, Round Wire	—	—	—	7257B
159	Clincher Plate	—	7650A	—	7650A
160	*Clincher Pivot Stud	—	7258	—	7258
161	*Clincher Plate Distance Stud	—	7259	—	7259
162	Clincher Slide Strap	—	7256	—	7256
163	Clincher Slide Strap Rivet	—	7260	—	7260
164	Clincher Plate Binder Screw	—	9081	—	9081
165	Clincher Plate Binder Screw Plate	—	18179	—	18179
166	Clincher Slide	—	18182	—	18182
167	Clincher Slide Adj. Block	—	18183	—	18183
168	Clincher Slide Adj. Block Clamp	—	18184	—	18184
169	Clincher Slide Adj. Block Clamp Screw	—	UA3216.2	—	UA3216.2
170	Clincher Slide Adj. Screw	—	18186	—	18186
171	Clincher Slide Adj. Screw Binder	—	38	—	38
172	Driver Release Pin	5160	5160	5160	5160
173	Staple Wire Oiler Plate	2165	2165	2165	2165
174	Oiler Felt Retainer	2166	2166	2166	2166
175	Oiler Felt	2167	2167	2167	2167

* Part Should Be Installed By Bostitch Service Man.

† Included in 27207A Assembly

VARIABLE CROWN AND WIRE PARTS

Index #	Name and Description	Part Number			
		15001DHD SERIES	18001DHD SERIES	18001D27HD SERIES	18001DSHD SERIES
51	Face Plate				
	1/2 (12.7mm) - 103023 Ribbon Wire	15135CA	—	—	—
	1/2 (12.7mm) - 2 Hybar Wire	15135CA	—	—	—
	1/2 (12.7mm) - 2024 Bookbinders Wire	19135DA	19135DA	19135DA	—
	1/2 (12.7mm) - 20 Bookbinders Wire	19135DA	—	—	—
	1/2 (12.7mm) - 23 Bookbinders Wire	—	—	—	19135DA
	1/2 (12.7mm) - 25 Bookbinders Wire	—	—	—	19135DA
	5/8 (15.9mm) - 20 Bookbinders Wire	—	—	—	15636CA
	5/8 (15.9mm) - 2024 Bookbinders Wire	—	—	—	15636CA
	5/8 (15.9mm) - 23 Bookbinders Wire	—	—	—	15636CA
	5/8 (15.9mm) - 25 Bookbinders Wire	—	—	—	15636CA
	3/4 (19.1mm) - 10302 Ribbon Wire	15635DA	—	—	—
46	Swivel				
	1/2 (12.7mm) - 103023 Ribbon Wire	15066BA	—	—	—
	1/2 (12.7mm) - 2 Hybar Wire	15070A	—	—	—
	1/2 (12.7mm) - 2024 Bookbinders Wire	19065A	19065A	19065A	—
	1/2 (12.7mm) - 20 Bookbinders Wire	19065A	—	—	—
	1/2 (12.7mm) - 23 Bookbinders Wire	—	—	—	19065A
	1/2 (12.7mm) - 25 Bookbinders Wire	—	—	—	19065A
	5/8 (15.9mm) - 20 Bookbinders Wire	—	—	—	15565A
	5/8 (15.9mm) - 2024 Bookbinders Wire	—	—	—	15565A
	5/8 (15.9mm) - 23 Bookbinders Wire	—	—	—	15565A
	5/8 (15.9mm) - 25 Bookbinders Wire	—	—	—	15565A
	3/4 (19.1mm) - 103023 Ribbon Wire	15666BA	—	—	—
68	Stationary Wire Cutter				
	1/2 (12.7mm) - 103023 Ribbon Wire	15101	—	—	—
	1/2 (12.7mm) - 2 Hybar Wire	15101H	—	—	—
	1/2 (12.7mm) - 2024 Bookbinders Wire	15100-20W	15100-20W	15100-20W	—
	1/2 (12.7mm) - 20 Bookbinders Wire	15100-20W	—	—	—
	1/2 (12.7mm) - 23 Bookbinders Wire	—	—	—	15100-20W
	1/2 (12.7mm) - 25 Bookbinders Wire	—	—	—	15100-25W
	5/8 (15.9mm) - 20 Bookbinders Wire	—	—	—	15600-20W
	5/8 (15.9mm) - 2024 Bookbinders Wire	—	—	—	15600-20W
	5/8 (15.9mm) - 23 Bookbinders Wire	—	—	—	15600-20W
	5/8 (15.9mm) - 25 Bookbinders Wire	—	—	—	15600-25W
	3/4 (19.1mm) - 103023 Ribbon Wire	15601	—	—	—
81	Bender Bar				
	1/2 (12.7mm) - 103023 Ribbon Wire	15023A-103023W	—	—	—
	1/2 (12.7mm) - 2 Hybar Wire	15023HA-2HYBW	—	—	—
	1/2 (12.7mm) - 2024 Bookbinders Wire	19022A	19022A	19022A	—
	1/2 (12.7mm) - 20 Bookbinders Wire	15022A-20W	—	—	—
	1/2 (12.7mm) - 23 Bookbinders Wire	—	—	—	15022A-23W
	1/2 (12.7mm) - 25 Bookbinders Wire	—	—	—	15022A-25W
	5/8 (15.9mm) - 20 Bookbinders Wire	—	—	—	15522A-20W
	5/8 (15.9mm) - 2024 Bookbinders Wire	—	—	—	15522A-2024W
	5/8 (15.9mm) - 23 Bookbinders Wire	—	—	—	15522A-23W
	5/8 (15.9mm) - 25 Bookbinders Wire	—	—	—	15522A-25W
	3/4 (19.1mm) - 103023 Ribbon Wire	15623A	—	—	—
105	Driver				
	1/2 (12.7mm) - 103023 Ribbon Wire	15012	—	—	—
	1/2 (12.7mm) - 2 Hybar Wire	15012H-2HYBW	—	—	—
	1/2 (12.7mm) - 2024 Bookbinders Wire	19011	19011	19011	—
	1/2 (12.7mm) - 20 Bookbinders Wire	15011-20W	—	—	—
	1/2 (12.7mm) - 23 Bookbinders Wire	—	—	—	15011-23W
	1/2 (12.7mm) - 25 Bookbinders Wire	—	—	—	15011-25W
	5/8 (15.9mm) - 20 Bookbinders Wire	—	—	—	15511-20W
	5/8 (15.9mm) - 2024 Bookbinders Wire	—	—	—	15511-2024W
	5/8 (15.9mm) - 23 Bookbinders Wire	—	—	—	15511-23W
	5/8 (15.9mm) - 25 Bookbinders Wire	—	—	—	15511-25W
	3/4 (19.1mm) - 103023 Ribbon Wire	15612	—	—	—

CROSS REFERENCE FROM PART NUMBER TO INDEX NUMBER

<u>Part Number</u>	<u>Index Number</u>	<u>Part Number</u>	<u>Index Number</u>	<u>Part Number</u>	<u>Index Number</u>	<u>Part Number</u>	<u>Index Number</u>
0041	129	9103	150	15076	52	18179	165
38	171	850699	134	15086	65	18182	166
56	145	850699	151	15087	66	18183	167
110	6	9140	67	15088	120	18184	168
257	27	9146	135	15089	121	18186	170
281	93	9146	152	15092B	31	19011	105
425	147	9147	132	15097B	115	19017A	109
2110B	125	9147	149	15098	118	19020	113
2110B	128	11057	19	15098B	118	19021	114
2110B	141	14596	42	15100-20W	68	19022A	81
2165	173	14597	78	15101	68	19031	96
2166	174	14598	77	15101H	68	19065A	46
2167	175	15001BA	1	15102	69	19078A	57
2245	10	15001BA-3/4	1	15104	70	19079	60
5037B	75	15011-20W	105	15105E	16	19080	58
5037B	108	15012	105	15106	17	19081	59
5062	37	15012H-2HYBW	105	15110	76	19084A	63
5160	172	15015A	106	15113A	71	19085	64
7024B	158	15016A	106	15116B	73	19121	34
7155	9	15022A-20W	81	15118	72	19121B	34
7180	35	15023A-103023W	81	15123	23	19122B	22
7224	74	15023HA-2HYBW	81	15130	18	19128A	33
7232	47	15024	83	15135CA	15	19130	18
7233	48	15025	85	15142	26	19133	20
7234	49	15026	86	15150A	131	19134	21
7256	162	15027	88	15151A	124	19135DA	15
7257B	158	15031	95	15152	126	19142	26
7258	160	15032A	97	15154	142	19147A	36
7259	161	15033	82	15155	143	19148	28
7260	163	15034A	100	15156	144	27117D	142
7650A	159	15035	101	15161	13	27207A	116
9002	7	15038	102	15553A	90	85018	30
9010	107	15039	99	15601	68	LW10.4	41
9044	56	15041	103	15605B	16	LW10.4	61
9044	77	15042	103	15612	105	PW10	79
9055	29	15045	38	15613BA	71	UA2208.1	104
9057	62	15046BA	122	15623A	81	UA3214.1	40
9059	24	15048	123	1565DA	15	UA3216.2	169
9065	137	15053A	90	15645	38	UA3808.9	32
9065	153	15054	92	15653A	90	UA3808.9	78
9067	140	15056	93	15661	39	UA3410.1	53
9067	154	15057	94	15666BA	46	UA4808.2	119
9068	136	15060	49	17288	146	UA5812.11	14
9068	155	15061	39	17291A	148	UB2106.6	98
9069	139	15066BA	46	18001BA	3	UB3108.1	2
9069	156	15070A	46	18001BA-3/4	3	UB3108.1	4
9070	157	15071	47	18002	5	UB3118	91
9070	138	15072B	51	18005A	8	UB3808.3	50
9081	164	15073A	54	18150A	127	WN1420	80
9103	133	15075	55	18152	130		