

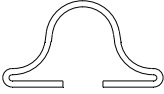

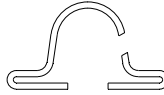

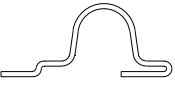

**FELT WIPE PADS  
LUBRICATION  
AND MAINTAINANCE:  
(FIGURE 1)**

**For stitcher head lubrication  
(required after each spool of wire)  
see page 5 of Magnatek Manual**

**IMPORTANT!** In order for the stitchers to operate properly, the felt wire wipes **MUST** be rotated and dampened with SAE 20W oil before each new spool of wire (50,000 to 70,000 stitches). Replace felt pads when they become so dirty that they cannot be rotated to a clean spot.

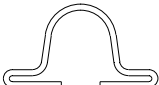
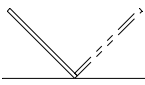
# MAGNATEK Loop Head Trouble Shooting

TROUBLE	POSSIBLE CAUSE	REMEDY
 <p><i>Shoulders not fully formed.</i></p>	<ol style="list-style-type: none"> <li>1. Worn Driver End.</li> <li>2. Driver Bar bent away from Driver End.</li> </ol>	<ol style="list-style-type: none"> <li>1. Replace Driver End.</li> <li>2. Straighten or replace.</li> </ol>
 <p><i>Fractured Loop.</i></p>	<ol style="list-style-type: none"> <li>1. Worn Driver</li> <li>2. Hard wire.</li> <li>3. See No. 4, Page 9.</li> <li>4. Sharp corner on Rotator forming edge.</li> </ol>	<ol style="list-style-type: none"> <li>1. Align Clinchers.</li> <li>2. Change wire spool.</li> <li>3. See No. 4, Page 9.</li> <li>4. Stone radius on forming edge of Rotator.</li> </ol>
 <p><i>Narrow Loop, left leg clinches outward.</i></p>	<ol style="list-style-type: none"> <li>1. Clinchers not properly aligned.</li> <li>2. Short wire draw. Length of leg varies.</li> </ol>	<ol style="list-style-type: none"> <li>1. Align Clinchers.</li> <li>2. See No. 3, Page 8.</li> </ol>
 <p><i>Approximately 1/2 Loop form occurs every other stitch. (Left side only)</i></p>	<ol style="list-style-type: none"> <li>1. Bender Bar Latch not fully engaged in Driver Bar retaining slot.</li> <li>2. Worn Bender Bar Latch.</li> <li>3. Worn Driver Bar.</li> </ol>	<ol style="list-style-type: none"> <li>1. Adjust Faceplate downward until Gripper snaps closed.</li> <li>2. Replace.</li> <li>3. Replace.</li> </ol>
 <p><i>Loop pulls out of paper.</i></p>	<ol style="list-style-type: none"> <li>1. Improper stroke adjustment. Driver Bar not pushing supporter back far enough.</li> <li>2. Worn Driver Bar End.</li> </ol>	<ol style="list-style-type: none"> <li>1. Adjust position of stroke downward.</li> <li>2. Replace.</li> </ol>
 <p><i>Leg or legs penetrate paper.</i></p>	<ol style="list-style-type: none"> <li>1. Excessive leg length.</li> <li>2. Excessive clinch.</li> </ol>	<ol style="list-style-type: none"> <li>1. Adjust Faceplate downward.</li> <li>2. Lower Clinchers.</li> </ol>
 <p><i>Paper shears under shoulder of loop.</i></p>	<ol style="list-style-type: none"> <li>1. Excessive compression.</li> <li>2. Excessive clinch.</li> </ol>	<ol style="list-style-type: none"> <li>1. Adjust Faceplate upward.</li> <li>2. Lower clinchers.</li> </ol>
 <p><i>Loop slants forward or backward.</i></p>	<ol style="list-style-type: none"> <li>1. Stitcher head not aligned with clinchers.</li> </ol>	<ol style="list-style-type: none"> <li>1. Loop slants forward - move head out. Loop slants backward - move head in.</li> </ol>
 <p><i>Excessive right leg length - over half of crown.</i></p>	<ol style="list-style-type: none"> <li>1. Worn supporter.</li> <li>2. Worn Driver End.</li> </ol>	<ol style="list-style-type: none"> <li>1. Replace supporter.</li> <li>2. Replace Driver End.</li> </ol>

For additional information on trouble shooting refer to pages 8, 9, and 10 of Magnatek Manual.

# MAGNATEK Loop Head

Parts List\* For MAGNATEK Stitcher Head With Loop Stitch Option

\* Refer to Magnatek Manual Parts List for all parts not shown.

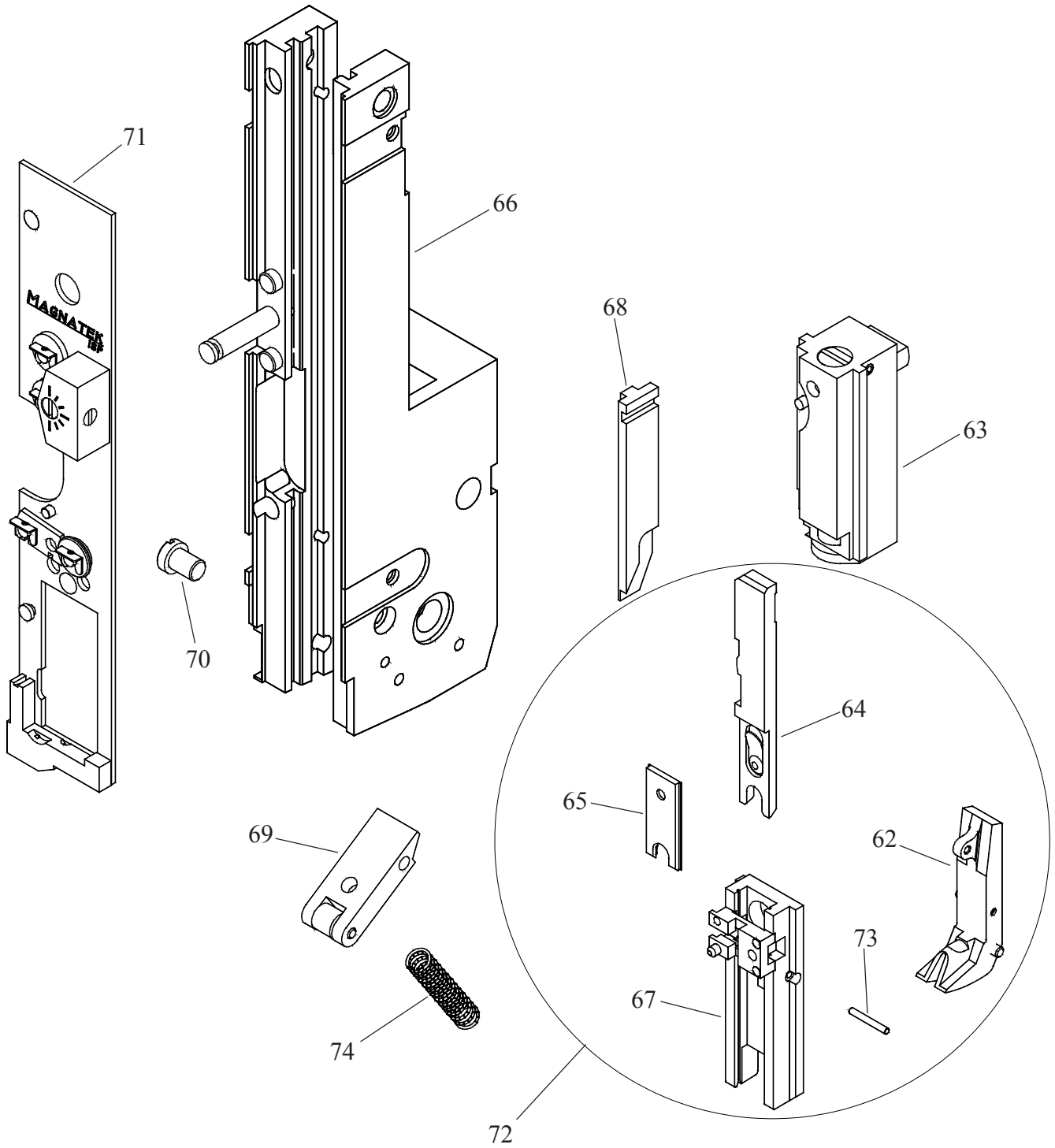

# MAGNATEK Loop Head parts list

Index Number	Part Number	Part Name	A	P	400	500 600 650 700	Special
62	CAA9026F	Supporter Assembly	*	*	*	*	
63	CTT2623E	Driving Slide Assembly w/CT2602 Connecting Lug		*		*	
	CTT2623D	Driving Slide Assembly - Rosback					*
	CAA2623A	Driving Slide Assembly w/CA2103 Connecting Lug	*		*		
	CTT2623C	Driving Slide Assembly - BinderyMate					*
64	CAA9012G	Driver Bar Assembly	*	*	*	*	
	CAA9012H	Driver Bar Assembly - McCain					*
65	CA9009F	Driver	*	*	*	*	
66	CAA2004C	Bonnet Casting Sub-Assembly	*		*		
	CTT2604C	Bonnet Casting Sub-Assembly - Macey, Omnibinder, Bourg		*		*	*
	CTT2604D	Bonnet Casting Sub-Assembly - McCain, Rosback (201&203)					*
	CTT2604G	Bonnet Casting Sub-Assembly - Watkiss, BinderyMate					*
67	CAA9013X3	Bender Bar Sub-Assembly	*	*	*	*	
	CAA9013Z3	Bender Bar Sub-Assembly - McCain					*
68	CA147A	Supporter Cam Plate	*	*	*	*	
69	CAA9036A	Supporter Spring Lever	*	*	*	*	
	CAA9036B	Supporter Spring Lever - Watkiss, Duplo					*
70	CA9044B	Swivel Holder Screw	*	*	*	*	
71	CAAA2132J	Faceplate	*	*	*	*	
72	CAAA9013Y3	Bender Bar Assembly	*	*	*	*	
	CAAA9013A4	Bender Bar Assembly - McCain					*
73	CA9029A	Supporter Pivot Pin	*	*	*	*	*
74	CA9032C	Supporter Spring	*	*	*	*	*

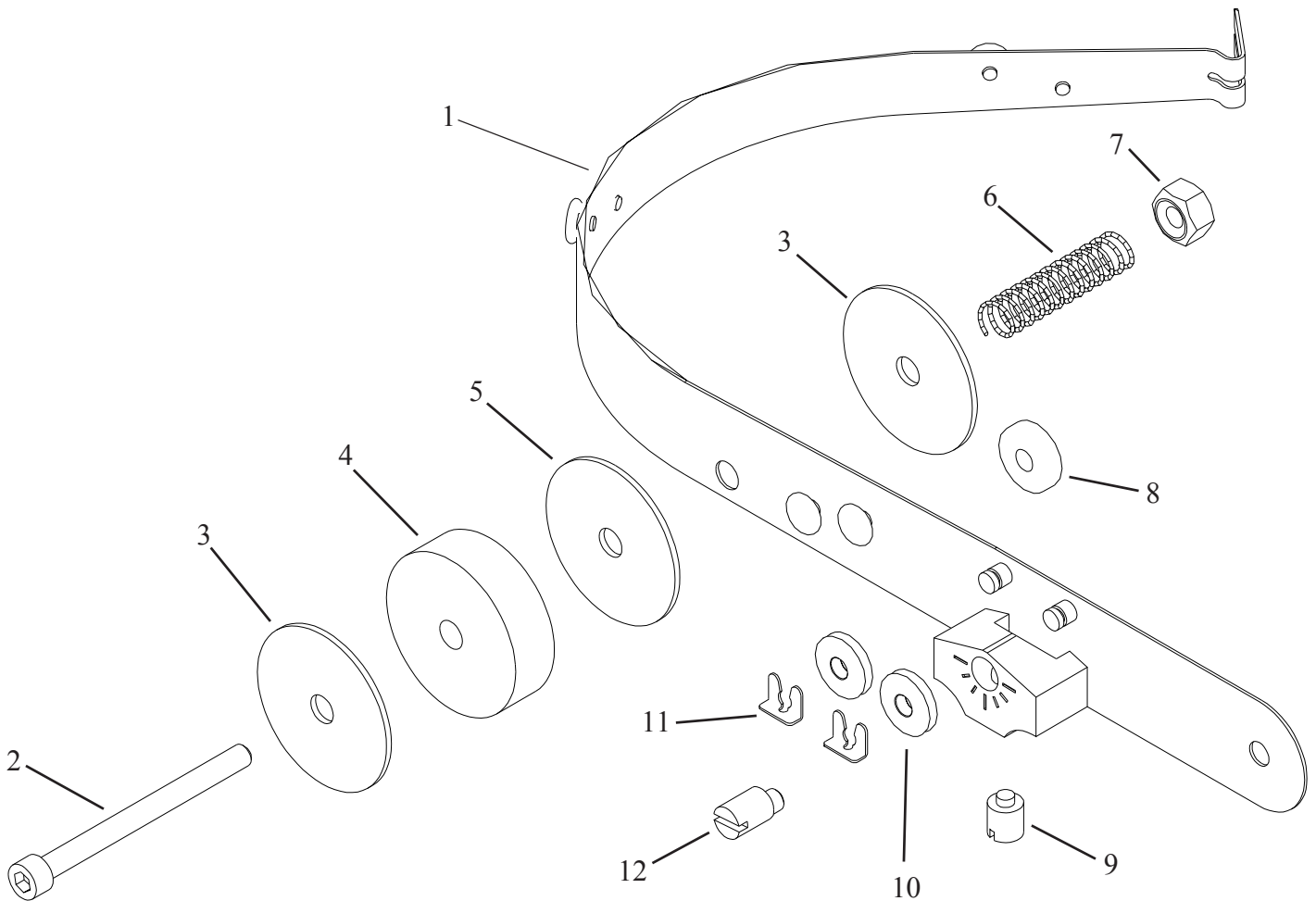

(SK883 Scene 5)

ITEM	PART NO.	DESCRIPTION	QTY
1	See Figures	Wire Guide Spring Assembly	
a	CAAA2133W		
b	CAAA2133B2		
c	CAAA2133L5		
d	CTTT2133C2		
e	CTTT2133D2		
NOTE: Most of the above Wire Guide Spring Assemblies include the following parts through 12:			
		Wire Guide Spring Assembly	1
a,c	CAA2133W		
b	CAA2133B2		
d	CTT2133C2		
e	CTT2133D2		

ITEM	PART NO.	DESCRIPTION	QTY
2	CB651E	Screw, 10-32 x 2.000	1
3	CA9651	Washer	2
4	CA9652	Felt Washer, Thick	1
5	CA9653	Felt Washer, Thin	1
6	CA9032C	Spring, Compression	1
7	CB860B	Nut, 10-32, Elastic Stop	1
8	CA9065A	Roller, Eccentric	1
9	CA172	Screw, Nylon Tip	1
10	CA9103C	Roller, Wire Straightener	2
11	CA9124	Clip, Roller	2
12	CA9066A	Eccentric	1

